

MODERN

MUSCLE

PERFORMANCE

Mustang | Camaro | Challenger | Charger | Corvette



California Carsmetics
1052 Brydges St.
London, Ontario
N5W 2B4
519-457-6004 Fax 519-457-6095

INDEX

Manufacturer

A	Ford Racing6, 13
Accel5, 31	
AFE.....2, 28	
Airaid.....2, 28	
American Racing13	
.....26, 37, 38	
ARP20, 32	
Auburn Gear11	
Auto Meter.....5, 18	
B	
B&G Suspension12	
B&M.....11, 24	
BBK.....2, 4, 7	
.....8, 15, 17, 30	
Borla.....3, 4	
.....16, 29, 30	
C	
Centerforce.....11, 24	
Clevite20	
Cloyes7, 20	
Comp Cams.....7, 15	
.....20, 32	
Competition Clutch11	
Corsa.....4, 16, 29	
Cragar13, 26	
D	
Diablosport5, 18, 31	
Dynamax4, 17, 30	
E	
Eagle19	
EBC Brakes.....10, 23, 34	
Edelbrock7, 8, 15	
.....19, 21, 32	
Eibach12, 25, 36	
Energy Suspension12	
.....25	
F	
Fidanza.....11, 24, 35	
Flowmaster.....3, 4, 17, 30	
Fluidampr7, 21	
	GM Performance.....19
	GT Styling39
	H
	Hawk Performance10
23, 34
	Haynes2, 28
	Holley21
	Hotchkis25, 36
	Hurst11, 13, 24
26, 35, 37
	Hypertech18, 31
	J
	JBA.....30
	K
	K&N.....2, 15, 28
	Keystone Restyling39
	Konig.....13, 26, 37
	KW Suspensions12
25, 36
	L
	Lakewood.....9, 12
22, 33, 35
	Lexani.....13, 37
	M
	Magnaflow3, 4, 16, 29
	Manley20
	Maxxis.....13, 26, 37
	MBRP17, 30
	Meguiar's.....39
	Melling21
	MGP Caliper Covers10
23, 34
	Mickey Thompson.....13
26, 37
	Moroso7, 21, 32
	Mr. Gasket9, 20
21, 22, 33
	MSD5, 18, 31

N	Nitrous Express.....2
O	Optima.....31
P	Pacesetter17
	Power Slot10, 23, 34
	Primax.....13
	Professional Products2
15, 21
	Prothane.....24, 35
	Putco.....40, 41
R	Richmond24
	Royal Purple24, 35
S	Scat.....19
	Snow Performance2
	SRP Professional.....19
	Street Scene.....39
	Sunpro.....5, 18, 31
	Superchips5, 18
T	T-Rex.....39
	Taylor18
	Toyo Tires13, 26, 37
U	Ultra13, 26, 37
V	V-Tech39
	Volant28
	Vortech.....8, 32
	Voxx26, 37
W	Wheel Replicas26, 37
Z	Zex.....8, 28

Product

A	Fuse Box Cover.....9	Pulley Sets.....7
22, 33	
Air Filters.....28		R
Air Separators.....32		Repair Manuals.....2, 28
B	Gaskets9, 20, 22, 33	Ring & Pinions24
Batteries.....31	Gauges5, 18	Rocker Arms20
Body Styling39	Grilles.....39	Roll Control.....24, 35
Brake Pads10, 23, 34	H	Rotating Assemblies19
Bushing Sets12, 25	Harmonic Balancers.....21	Rotors.....10, 23, 34
C	Harmonic Dampers.....21	S
Caliper Covers10	Head Bolt Kits6, 20	Shifters.....11, 24, 35
.....23, 34	Headers.....4, 17, 30	Shocks12, 35
Camshaft Kits7, 19, 32	Hood Scoops.....39	Spark Plugs31
Cap Covers9, 22, 33	I	Springs.....12, 25, 36
Chrome Trim40	Ignitions.....5, 18, 31	Strut Tower Braces9
Cleaners/Protectants.....39	Ignition Wires.....1822, 33
Clutches11, 24	Intakes2, 15, 28	Superchargers8
Coilovers.....12, 25, 36	L15, 32
Coils5, 18, 31	Light Bulbs41	Sway Bars25, 36
Connecting Rods.....6, 19	Light Covers39	T
Connectors9, 22, 33	M	Tachometers.....5, 18, 31
Control Arms.....9	Manifolds.....2, 8, 15, 32	Thermostats21
Couplers.....24, 35	Manifold Bolts.....20	Throttle Bodies2, 15
Cylinder Heads6	Mufflers.....4, 17, 30	Timing Sets7, 20
.....19, 32	Mustang Accessories.....39	Tires13, 26, 37
D	Mustang Packs6	Trailer Arms22
Differentials.....11	N	V
Door Sill Plates9	Nitrous Systems2	Valves.....20
.....22, 338, 28	W
E	O	Water Injection Kits.....2
EFI Systems.....21	Oil.....24, 35	Water Pumps.....7, 21
Engines6, 19	Oil Pans7, 21	Wheels13, 26
Engine Bearings.....20	Oil Pumps2137, 38
Engine Dampers7	P	
Exhaust Systems3, 4	Performance	
.....16, 17	Handling12, 25, 36	
.....29, 30	Pistons19	
Expansion Tanks7, 32	Power Steering Tanks7	
F32	
Flywheels11, 24, 35	Programmers/	
Fuel Rail Kits.....21	Modules.....5, 18, 31	

The publishers are not responsible for typographical errors.
Copyright© 2012. All rights reserved. All text, graphics, pictures, logos, and the selection and arrangement thereof is the exclusive property of the Publisher, or its content supplier. No portion of this publication, including images, may be copied or reproduced in any form without the prior written consent of the Publisher.

See These Catalogs For More Products!

These Titles Also Available...

Toyota • Jeep® • Professional • Towing • Serious Performance
Sport Compact Performance • Diesel Performance

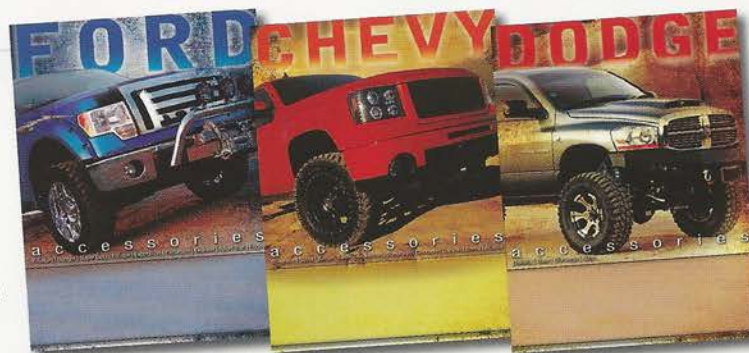

FORD MUSTANG



What's Inside!

Intake:	Page 2
Intake Manifold, High-Flow Intake Systems, Nitrous System, Repair Manuals, Methanol Injection.	
Exhaust:	Pages 3-4
Stainless Steel Exhaust Systems, Performance Headers, Exhaust Systems, Mufflers.	
Ignition:	Pages 6, 7, 8
VIVID, LINQ, Intune, Replacement Coils, Ignition Control, Launch Master, Ultra-Lite Gauges, Sun Super Tachs®.	
Engine:	Pages 6, 7, 8
Power Upgrade Pack, Drag Pack, Handling Pack, Cylinder Heads, Crate Engines, Cam Gear Set, SPR Hydraulic Roller Cams, True Roller Timing Sets, Underdrive Performance Pulley Sets, Engine Dampers, Power Steering Tanks, Oil Pans, Coolant Expansion Tanks, Power Steering Tanks, Intake Manifolds, Superchargers, Nitrous Systems.	
Mr. Gasket:	Page 9
Cap Covers, Ultra-Seal Exhaust Gaskets, Differential Rear End Gasket, Fuse Box Cover, Door Sill Plates, Oil Pan Gaskets, Lower Control Arms, Upper Control Arms, Panhard Rod, Strut Tower Brace, Subframe Connector, Control Arm Relocation Brackets, Rear Sway Bar End Links.	
Brakes:	Page 10
Brake Pads, Caliper Covers, Brake Rotors.	
Drivetrain:	Page 11
Dual Friction® Clutch, Shifters, Aluminum Flywheels, Differentials.	
Suspension:	Page 12
Coilovers, Handling Package, Springs, Control Arm Bushing Sets, Shocks.	
Wheels:	Page 13
Classic Styles, New Looks, Performance Tires.	



AIR INTAKE

Professional Products™

TYPHOON™ Intake Manifold

99-04 4.6L 2V Ford Mustang

- Chassis dyno proven to produce 21.5 more rear wheel hp than a stock manifold at 6,500 rpm
- More torque from 4,000 rpm on up
- Three-piece design that allows easy access to the bottom and the middle of the plenum chamber along with the runners for those who want to do their own additional port and plenum fine tuning
- Bolt-in replacement for all 1999 to 2004 engines and uses the stock alternator and all other stock engine accessories

Part No. 54060 - Polished

Part No. 54061 - Satin

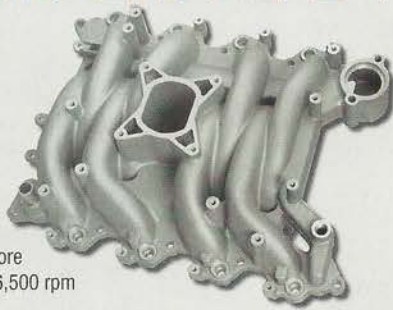

High-Flow Intake Systems

- Guaranteed horsepower
- Increased filtering capacity
- Lifetime high-flow air filter
- Won't void factory warranty
- K&N Million Mile Limited Warranty®



Application	Note	Part No.	HP Gain
11-13 Mustang GT 5.0L	—	632578	+20.27 HP
2005 Mustang GT 4.6L	1	572565	+15.26 HP
96-04 Mustang GT 4.6L	1	5725193	+10.07 HP
06-09 Mustang GT 4.6L	2	632565	+15.26 HP
03-04 Mustang Mach 1 4.6L	1	572555	+11.6 HP
07-08 Mustang Shelby 5.4L	2	572571	+53.71 HP
03-04 Mustang SVT Cobra 4.6L	1	572545	+30.28 HP

1) Street Legal in 50 states 2) Street Legal in most states, not legal for use on emission controlled vehicles in the state of CA.



Twin 62mm Throttle Body

- Bolt-on 14-15 horsepower at the wheels with no other modifications
- OEM-style electronic throttle

Part No. 1763 - 05-10 Twin 62mm Throttle Body - Mustang GT

Part No. 1764 - 07-10 Twin 65mm Throttle Body - GT500

Part No. 1765 - 05-10 Mustang V6/4.0L 70mm Throttle Body



Stage 2 Intake Systems

- aFe Cold Air Intakes outperform all other intakes and produce increased horsepower, torque, and MPGs
- Replaces the stock intake tract and directs increased air flow with improved volumetric efficiency for maximum performance
- Pro 5R washable/reusable conical air filter improves airflow for increased horsepower and torque

Part No. 5410292 - 05-09 Ford Mustang 4.6L

Part No. 5411782 - 2010 Ford Mustang 4.6L

Part No. 5411982P - 11-12 Ford Mustang 5.0L



Stage 2 Boost Cooler™ Water / Methanol Injection Systems

This kit uses manifold boost pressure to determine when and how much fluid to inject. Proportionally injecting according to boost pressure gives the most accurate delivery of water-methanol and allows the most cooling and performance improvement over the widest range. More power and driveability is the result. It can be used on any forced induction engine: carbureted, fuel injected, turbocharged, positive displacement, or centrifugal blowers. For higher boost applications (over 25psi), the controller can be upgraded to our VC100 unit. Now with Lifetime Warranty - please see details.

Kit includes:

- 150+ PSI high volume pump
- 3 Quart reservoir
- Digital variable controller
- 2 Nozzles to cover a wide range of horsepower
- All required hardware needed for installation
- Comprehensive instructions



Part No. 20010 - Mustang w/ Centrifugal S/C or Large Turbo

Part No. 20011 - Mustang w/ Positive Displacement S/C or Small Turbo



The Performance Intake Company

Intake Systems

- Improved horsepower, torque, and fuel efficiency
- Washable, reusable hi-flow filter
- Easy bolt-on installation
- Filtration down to 2 microns
- Lifetime "no-hassle" warranty

Part No. 450238 - 2010 Mustang GT 4.6L

Part No. 450172 - 05-09 Mustang GT 4.6L

Part No. 450264 - 11-12 Ford Mustang GT 5.0L



Mustang Nitrous System

Is your 4.6 liter 2 valve motor a little light on torque and horsepower? Nitrous Express has the solution to your problem! Designed for superior distribution and atomization, this plate-style nitrous system is unmatched in performance and reliability. 50 to 150 wheel horsepower, tons of mind bending torque, and no hood clearance problems!

Part No. 2094610 - 96-04 Mustang 4.6L 2V engines

Part No. 2094710 - 05-10 Mustang 4.6 L 3V engines

Part No. 2093210 - 2011 Mustang 5.0L 4V engines

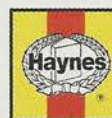

Automotive Repair Manuals

Every manual is based on a complete teardown and rebuild.

Part No. 36051 - Ford Mustang 94-04

Part No. 36052 - Ford Mustang 05-10

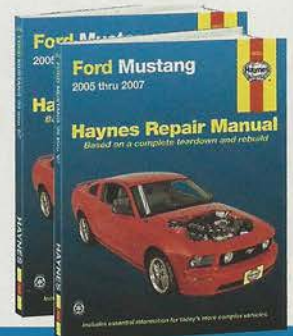



Stainless Steel Exhaust Systems

- Mandrel-bent stainless steel tubing
- Polished, fully adjustable stainless steel tips
- Straight-through stainless steel Magnaflow Performance Mufflers

Part No.	Year	Description
Mustang 2010 4.6L GT		
16570	2010	Dual Split Rear, Cat-Back
16571	2010	2.5" Magnapack System, Dual Split Rear, Cat-Back
16572	2010	3" Magnapack System, Dual Split Rear, Cat-Back
Mustang 2010 4.6/5.4L GT/GT500		
16573	2010	Dual Split Rear, Axle-Back
16574	2010	2.5" Magnapack System, Dual Split Rear, Axle-Back
Mustang 05-09 4.6L V-8 GT/Shelby GT/Bullitt Cat-Back		
15881	05-09	MagnaFlow Dual Exhaust System, 2.5"
15883	05-09	Magnapack Dual Exhaust System, (aggressive tone), 2.5"
16674	05-09	Magnapack Dual Exhaust System, (aggressive tone), 3"

Part No.	Year	Description
Axle-Back		
15882	05-09	MagnaFlow Dual Exhaust muffler replacement, 2.5"
16793	05-09	Magnapack Dual Exhaust, (aggressive tone), 2.5"
16843	05-09	4.6L V-8, Muffler-Delete, (aggressive tone), 2.5"
Mustang 05-09 4.0L V-6		
16605	05-10	MagnaFlow Dual Exhaust System, (dual split rear, V-8 look), Cat-Back
15889	05-10	Muffler Replacement, single exit, Axle-Back
Mustang 11-12 5.0L GT and 5.4L Shelby GT500		
15589	11-12	Dual Split Rear, Street Series, Cat-Back
15590	11-12	Dual Split Rear, Competition Series, Cat-Back
15593	11-12	Dual Split Rear, Street Series, Axle-Back
15594	11-12	Dual Split Rear, Competition Series, Axle-Back



American Thunder and Force II Exhaust Systems

- Reduced backpressure for improved acceleration and towing power
- Cooler underhood temperatures
- A cleaner and more efficient burn in the combustion chambers
- Better fuel economy
- And that one and only Flowmaster sound!



American Thunder Part No.	Force II Part No.	Application
17215	—	1998 Mustang GT/ Cobra
17277	—	1998 Mustang LX (V6)
17312	17267	99-04 Mustang GT/Bullitt/Mach I
—	17275	99-04 Mustang LX (V6)
17410	—	05-10 Mustang GT
17421	—	05-09 Mustang (V6)
817496	—	11-12 Mustang GT 5.0L, 40 Series Classic Mufflers, Axle-Back
817500*	817503*	11-12 Mustang GT 5.0L, 60 Series Mufflers, Cat-Back

† Tips not included *Stainless Steel



Stainless Steel Exhaust Systems

- Relieves backpressure for improved horsepower and torque
- Aircraft-quality stainless steel construction
- Easy and quick bolt-on installation



Part No.	Description
Mustang GT, 5.0L V8 AT/MT	
140370	11-13 Cat-Back™ System "S-Type" split rear
140371	11-13 Cat-Back™ System split rear
140372	11-13 Cat-Back™ System Aggressive "ATAK" split rear
Mustang GT, 4.6L V8 AT/MT	
11778	2010 Axle-Back System "Touring" 2.5" split rear 4" RD x 12"
140318	2010 Cat-Back™ System "S-Type" 2.5" split rear 4" RD x 12"
14834	99-04 Cat-Back™ System 2.5" split rear 4" RD x 14"
140067	99-04 Cat-Back™ System "S-Type" 2.5" split rear 4" RD x 12"
140135	05-09 Cat-Back™ System "S-Type" 2.5" split rear 4" RD x 12"
11750	05-09 Rear Section "S-Type" 2.5" split rear 4" RD x 12"
11752	05-09 Rear Section "Touring" 2.5" split rear 4" RD x 12"
Mustang Shelby GT 500, 5.4L V8 MT	
140320	2010 Cat-Back™ System w/X-pipe, 2.5" split rear 4" RD x 12"
140210	07-09 SC Cat-Back™ System W/ XR-1 2.5" split rear 4" RD x 12"
140222	07-09 Cat-Back™ System "Touring" 2.5" split rear 4" RD x 12"

EXHAUST

Borja
EXHAUST

Performance Headers

- Lightweight and durable stainless steel units
- Thick stainless warp-proof flanges, full merge collectors, and incredible performance
- For competition use only and are designed to be used with vehicles equipped with extensive performance upgrades



- Part No. 17237** - 05-10 Mustang GT 4.6L long tube w/X-Pipe
Part No. 17238 - 07-10 Mustang GT500 5.4L long tube w/X-Pipe
Part No. 17263 - 11-12 Mustang GT 5.0L long tube
Part No. 17273 - 2011 Mustang GT500 5.4L long tube

CORSA
PERFORMANCE EXHAUSTS

Exhaust System with RSC Technology

- Additional 13 horsepower and 9 lb/ft torque on chassis dyno
- 304 stainless steel construction, crafted with pride and precision in the USA
- Handcrafted, polished stainless steel single Pro-Series 4.0" tips
- Direct bolt-on installation; no cutting or welding required
- 50-state emissions legal



Part No.	Description
14314	05-10 Axle-Back XTREME Exhaust System w/ 4.0" Pro-Series Tips
14311	05-10 Sport - Dual Rear Exit w/ Single Pro-Series 4.0" Tips
14313	05-10 Ultimate Touring - Dual Rear exit w/Single Pro-series 4.0 Tips
14312	05-10 X0-pipe 2.5" for 4.6L V8 3v GT
14316	11-12 Sport - Dual Rear Exit Axle-Back w/ Single Pro-Series 4.0" Tips
14317	11-12 Axle-Back XTREME Exhaust System w/ 4.0" Pro-Series Tips
14318	11-12 X0-pipe 2.5" for 5.0L GT, Boss 302 & Laguna Seca

FLOWMASTER
THE EXHAUST TECHNOLOGY COMPANY

40 Series Mufflers Delta Flow

Mild performance sound, deep powerful tone, minimal interior resonance.

(A)	(B)	(C)	(D)	In/Out
Part No.	Part No.	Part No.	Part No.	Sizes
4" X 9.75" Case, 13" long body/19" overall				
942040	942041	942042	942043	2.0"
942440*	942441*	942442*	942443*	2.25"
942540	942541*	942542	942543*	2.5"
943040	943041*	943042*	943043	3.0"

*Available in 409 stainless steel, replace the "9" at the beginning of the part number with "8".



BBK
PERFORMANCE PARTS
Today's Performance

Headers

- 3/8" Thick laser-cut flanges
- Multiple magazine tests have confirmed a 17-23 rear wheel horsepower increase with full length headers



Part No.	Description
05-10 Mustang GT 4.6L	
1612	Tuned Length Shorty Headers - Chrome
16120	Tuned Length Shorty Headers - Ceramic
1641	Full Length Headers - Chrome
16410	Full Length Headers - Ceramic
96-04 Mustang GT 4.6L	
1615	1-5/8" Tuned Length Shorty Header - Chrome
16150	1-5/8" Tuned Length Shorty Header - Ceramic
11-12 Mustang GT 5.0L	
1632	Mid-Length Headers - Chrome
16320	Mid-Length Headers - Ceramic
1633	Full Length Headers - Chrome
16330	Full Length Headers - Ceramic

Thrush

Hush Thrush™ Super Turbo™ Mufflers

- That vintage sound you love with the performance you expect
- The improved tri-flow design enhances flow and performance
- All mufflers are reversible for maximum installation and flexibility
- The perfect choice for that classic hot rod and today's muscle car



Part No.	Description
17631	2.25" In/Out, Offset/Center
17632	2.25" In/Out, Offset/Offset
17633	2.5" In/Out, Offset/Center
17634	2.5" In/Out, Offset/Offset
17635	3" In/Out, Offset/Center
17636	3" In/Out, Offset/Offset

MAGNAFLOW
Exhaust
PRODUCTS

Stainless Steel Race Series Mufflers

- Significantly reduce DB levels on high-performance vehicles without any loss in performance
- Straight through design
- Features a stainless steel body, end caps and perforated core, and a stainless weld bead



Part No.	Part No.	Inlet/Outlet	Body Length	Overall Length
5" x 8" Oval		6" Round		
14150	14160	3.5"	6"	12"
14151	14161	3.5"	14"	20"
14152	14162	4"	6"	12"
14153	14163	4"	14"	20"



VIVID LINQ

Superchips VIVID LINQ is the only tuning device in the industry designed to work with Android™ OS smartphones. LINQ is available for nearly 1,000 vehicle applications including most popular truck, performance car, and SUV's produced in the last decade. LINQ is a Bluetooth wireless vehicle tuning interface that turns your phone into a performance tuner, diagnostic trouble code tool, PID reader, driving coach, or virtual dash board with the touch of the phone screen. Combine your Android phone with LINQ for an affordable yet advanced vehicle tuning experience!



NEW



Features Android™ Technology

Part No. 118650
99-Up Ford Gas Vehicles

DIABLOSPORT®

GASOLINE AND DIESEL TUNING SYSTEMS



The DiabloSport inTune is the next generation of tuning tools, a total revolution in the tuning industry. The inTune contains innovative features not available anywhere else.

- Least expensive full color touchscreen available
- USB connectivity
- Easy to use
- Free automatic updater
- Removable cables
- External sensor inputs
- One part number for all applications, including gas and diesel
- Virtually no limit to the amount of custom tunes the inTune can hold
- Most adjustable parameters in the market
- Preloaded with multiple "canned" tunes for increased HP, TQ and MPG
- Designed, engineered and manufactured in the USA



NEW

Part No. I1000



SuperCoil Replacement Coils

- 10-15% more energy than the OEM coils
- These are direct plug replacements for OEM coils
- Specialized high-temperature epoxy resists shock and vibration, while increasing thermal conductivity
- Sold individually

Part No. 140032 - 98-08 Ford 4.6/5.4/6.8L modular 2 valve direct fire
Part No. 140033 - 04-08 Ford 4.6/5.4 modular 3 valve direct fire
Part No. 140034 - 97-08 Ford 4.6/5.4L modular 4 valve direct fire
Part No. 140060 - 11-12 Ford 5.0L modular



Digital-6 Plus Ignition Control

The heart of the Digital-6 Plus Ignition is a 15 MHz microcontroller, the fastest of all digital ignitions. There are also built-in features such as a Two Step Rev Control, a High Speed Retard, Magnetic Pickup Compensation, and an adjustable Start Retard. The new Digital-6 Plus Ignition installs easily to points or electronic ignitions. C.A.R.B. Approved: E.O. D-40-31

Part No. 6520



Ultra-Lite Gauges

- Race-proven design, styling, and accuracy
- Perfect for all applications
- Lightweight aluminum construction
- Easy-to-read silver dial
- Traditional reflective side lighting (not through dial)
- Red and green light bulb covers included

Part No.	Description
4344	Ultra-Lite Pyrometer, 01600°F, 2-1/16"
4305	Ultra-Lite Boost, 60 psi, 2-1/16"
4357	Ultra-Lite Trans. Temperature, 100-250°F, 2-1/16"
4304	Ultra-Lite Boost, 35 psi, 2-1/16"



Part No. 8734*
*Not legal for sale or use on pollution controlled vehicles.

Ford Launch Master

- Easily set a launch rpm for consistent holeshots
- Connects to the factory coils for easy installation
- The best way to launch hard

The Launch Master connects right to your late model Ford to produce consistent launches and quicker 60-foot times by setting an rpm limit to stage with.



Sun Super Tachs®

Sun Super Tachs® are the world's best recognized tachometers. Highly accurate. Fast needle response - 90% of full scale in 4/10 of a second.

Part No.	Description	Color
	Chrome Bezel	
CP7901	3-3/8" dial face	Black
CP7903	3-3/8" dial face	White



ENGINE

Mustang Power Upgrade Pack

- Bolt on Power Upgrade Package and get repeatable, safe, and SAE-proven horsepower
- The following Power Packs will increase your SVT Mustang by 40 HP, Mustang GT by 20 HP, or your V6 Mustang by 10 HP
- Kits include Cold Air Kit, Mufflers (Exhaust System for Mustang V6 only), Performance Oil Filter, and Ford Racing Performance Calibration. Parts also sold individually

Refer to your Ford Racing catalog for details.

Part No.	Application
M2007FR1SV	07-09 SVT Mustang
MFR1MGT	05-09 Mustang GT
MFR1MGTA	2010 Mustang GT
MFR1MGTB	11-12 Mustang GT

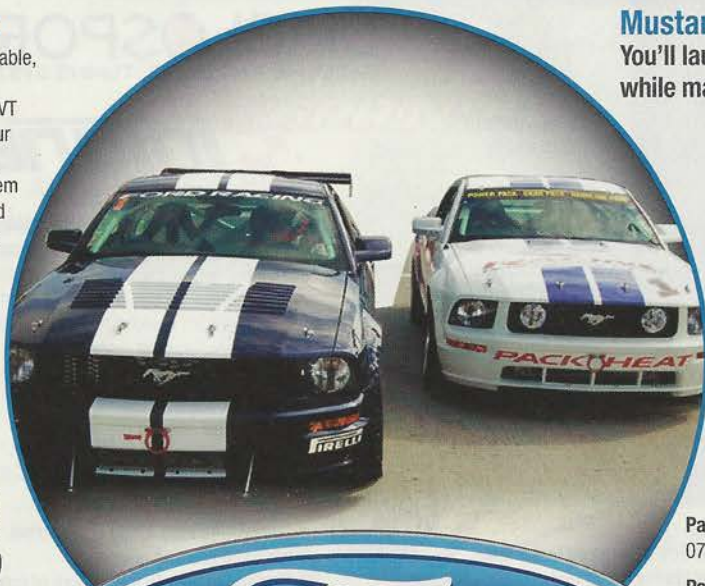

Mustang Drag Pack

You'll launch harder and accelerate faster while maintaining drivability!

- SVT Mustang Drag Pack includes a 113mm Cold Air Kit, 3.73 Ratio Ring and Pinion, Gear Installation Kit, Shorty Headers, a Short Throw Shifter designed by Ford Racing and Hurst, and a Performance Oil Filter
- Mustang GT Drag Pack includes a 90mm Cold Air Kit, a 4.10 Ratio Ring and Pinion (manual transmission), 3.73 Ratio Ring and Pinion (automatic transmission), Gear Installation Kit, Shorty Headers, a Short Throw Shifter designed by Ford Racing and Hurst (not included in the automatic transmission pack,) and a Performance Oil Filter

Part No. M2007FR2SV
07-09 SVT Mustang

Part No. M2006FR2
05-09 Mustang GT
Manual Trans



Mustang Handling Pack

Put a little "Road Race" into your 11-12 Mustang V6, GT or SVT!

- Uniquely tuned exclusively to fit 11-12 Mustang V6, GT Coupe, GT Convertible or SVT Mustang
- Handling Pack includes Dampers, Lowering springs, Upper strut mount, Jounce bumpers, Anti-roll bar kit and Strut Tower Brace
- All components are designed to work together as a package
- Lowers car approximately 1.0"
- Parts also sold individually



Part No.	Application
MFR3MSVT	11-12 SVT Mustang
MFR3MV6A	11-12 Mustang V6
MFR3MGTA	11-12 Mustang GT Coupe
MFR3MCGTA	11-12 Mustang GT Convertible



Refer to the Ford Racing catalog for details.

Part No. M6049P46 - Right Hand
Part No. M6050P46 - Left Hand

4.6L Power Improvement (PI) Cylinder Head

- Production 4.6L SOHC 2V aluminum cylinder heads
- Fully machined and assembled with production Mustang GT valvetrain and camshaft
- Great for custom engine builds
- 43.9 /- 1.5 cc combustion chamber raises compression on 1996-98 engines to 10:1



5.0L DOHC Aluminator Crate Engine

Ford Racing has taken the Mustang GT 5.0L 4V TiVCT engine and created another in its series of "Aluminator" crate engines built to deliver higher performance. The 5.0 Aluminator is built with extreme duty connecting rods and pistons designed specifically for high performance applications. Mahle forged pistons are hard anodized with Graphal low friction coating. The connecting rods are premium Manley H-beam with ARP 2000 bolts and fitted with BOSS 302 high performance bearings.

Part No. M6007A50NA - Naturally Aspirated
Part No. M6007A50SC - Supercharged

Mustang GT 5.0L Crate Engine

- 412+ horsepower @ 6500 rpm 390 ft.-lb.+ of torque @ 4250 rpm
- 11.0:1 Compression ratio
- Twin Independent Variable Camshaft Timing (Ti-VCT)
- Piston-cooling jets, optimized oil drainback and windage control improve high-rpm performance
- Lightweight aluminum cylinder block features cross-bolted main bearing caps and thick main bearing bulkheads for bottom-end strength
- Vehicle harness and PCM not included

Part No. M6007M50



H-Beam Connecting Rods

- Made from 4340 aircraft-quality material
- H-beam design is the strongest SCAT rod available
- Perfect for supercharged and nitrous applications
- Special doweled cap for specific cap-to-rod alignment
- Profiled clearance for stroker applications



Part No. 6593346
Ford 4.6L, 5.933" Length



Cylinder Head Studs

- ARP uses a premium-grade 8740 alloy that is rated far superior to "aircraft" quality
- Each stud is placed vertically in special racks and precisely heat-treated to 200,000 psi
- Each stud is centerless ground to make it as close to perfectly concentric as possible
- ARP studs are thread rolled after heat-treat, which gives them about 1000% (that's ten times) better fatigue strength than those studs that are threaded prior to heat-treat



Part No.	Description
1564101	4.6L & 5.4L 2V /4V, Hex
1564301	4.6L & 5.4L 2V /4V, 12 pt.
2564001	4.6L & 5.4L 2V/4V ARP2000, Hex
2564201	4.6L & 5.4L 2V/4V ARP2000, 12 pt.



Ford 4.6/5.4L SOHC and DOHC Adjustable Cam Gear Set

- Provides up to 12 degrees of camshaft advance or retard
- Comes equipped with proper sensor to install in exactly the same way as the original factory gears and work with the Ford OE timing chains
- Each gear features a billet aluminum hub and steel outer gear for heightened durability and light weight

Part No. 10246SET - Cam Gear Set



Hex-A-Just True Roller Timing Sets

- Kit includes all new Sprockets, Tensioners and Guides
- Adjustable Cam Sprockets – adjust your valve timing with the turn of a wrench
- Upgraded All-Steel Crank Sprocket – the OE sprocket is made of powdered metal
- Premium Roller Chains – These premium "fine finish" chains are made from high-strength steel components, pre-stressed and heat-treated for increased durability to handle all that extra horsepower

Part No. 93162A - 96-98 Mustang 4.6L

Part No. 93163A - 99-00 Mustang 4.6L



Performance Engine Dampers

- Provides maximum control of destructive crankshaft vibration at all engine speeds
- Extends crankshaft and bearing life
- Improves valve timing accuracy and ignition stability
- Increases horsepower and torque
- Requires no service or maintenance
- SFI accepted, explosion proof
- 100% satisfaction guarantee/100% American made



Part No. 660202 - 96-04 Ford 4.6L, Internally balanced, 6-3/4"

Part No. 740201 - 05-08 Ford 4.6 L, 5.4L, Internally balanced, 7-1/2"



American ingenuity and integrity, since 1968.

Ford Modular Oil Pan Wet Sump, 7 Quart Capacity, 6-1/2" Deep

Engine Application: 4.6/5.4L SOHC/DOHC, Fits: Rear Sump Mustang

- Increased oil capacity
- Oil sump retaining system
- Designed to work with factory 2v, 3v, and 4v oil pump pickup
- 1/2" NPT fitting for drain back
- Compatible with most starter/flywheel combinations
- Works with both SOHC and DOHC

Part No. 20546 — Oil Pan, Steel, Clear Zinc, Kicked-out Rear Sump



Coolant Expansion Tanks

- Direct bolt-in replacement to stock two-piece plastic tank
- Fabricated aluminum for strength; factory tanks fail after repeated high-heat situations
- This aluminum tank can be polished, chromed, powder-coated, or left as-is for a race look
- Uses factory stock vented cap, bleeds pressure like the factory intended
- Integral fittings are more reliable than screw-in style on competitor tanks

Part No. 63767 - Ford Mustang 1996-2004

Part No. 63768 - Ford Mustang 2005-2010

Part No. 63783 - Ford Mustang 2011-12



Xtreme Fuel Injection (XFI™) SPR Hydraulic Roller Cams

- Available for both naturally aspirated and supercharged engines
- Designed to work with a modified Ford variable cam timing (VCT) system
- For Ford 4.6/5.4L SOHC 3V engines

Part No.	RPM Range	Adv. Duration	Duration @.050"	Valve Lift	Sep. Angle
Naturally Aspirated					
127600	1000-7100	.547/.560	272/283	237/244	112
Blower Grind					
127550	950-6900	.547/.560	272/287	237/248	113
127650	1000-7100	.559/.560	280/295	245/256	113



BBK Underdrive Performance Pulley Sets

- Bolt on 10-20 horsepower
- Deliver full cooling and charging
- CNC-machined aluminum alloy
- Hand polished for great looks
- Simple bolt-on installation
- Use your existing serpentine belts



Part No. 1555 - 96-00 Ford Mustang 4.6 GT & Cobra (3 pc.)

Part No. 1556 - 01-04 Ford Mustang 4.6 GT & Cobra (3 pc.)

Part No. 1653 - 05-10 Ford Mustang 4.6 GT (2 pc. SFI rated)



High-Performance Water Pumps

- These "super cooling" pumps are computer-designed to deliver more flow at a higher velocity
- Precision cast powdered metal impellers have extra large vanes for the maximum flow rate possible, ensuring adequate pressure and volume even at lower engine speeds



Part No. 8803 - Short Style, Reverse Rotation, Fits 2002 Mustang GT and Cobra, 2003-04 Mustang GT, Cobra and Mach 1

Part No. 8804 - Long Style, Reverse Rotation, Fits 1996-01 Mustang GT and Cobra & 2005-2009 Mustang GT

Power Steering Tanks

- Manufactured from aluminum for strength and light weight
- Direct bolt-in to factory tank
- A much stronger and better looking tank than the plastic factory tank
- Baffled and complete with cap, integral mounting bracket, and fittings to ensure a factory replacement part

Part No. 63490 - 1999-2004 Mustang

Part No. 63491 - 2005-2010 Mustang



SUPERCHARGERS



A technically advanced centrifugal unit that does not require a connection between the engine oil pan and the compressor or gear case... no oil line.

07-08 Ford Mustang GT 4.6L (NOVI SL)

SL Systems Include:

- Remote fluid drain hose (attached to supercharger) that allows for simple oil changes without removing the supercharger from the vehicle
- Integrated dipstick for easy fluid checks
- Three 4oz bottles of lubricant for future fluid changes (supercharger uses 4oz of a unique synthetic formulation)



More Applications Available From Paxton & Vortech.

Part No. 1001852

Type: NOVI 2200SL High-Output (Polished finish shown)

Stock HP/TQ: 300/320

Paxton HP/TQ: 470/420

Boost (PSIG): 9-10

CARB E.O.: D-195-23

05-06 GT systems available



05-12 Ford Mustang Superchargers

- Allows you to boost your Mustang to a very impressive 466 flywheel hp and 439 ft./lbs. of torque
- Delivers instant, reliable and safe hp for a stock Mustang 4.6L with low boost for minimum stress on the engine
- Includes everything you need for a complete installation
- Clears stock hood and 50-state street legal
- Available with an optional warranty, 3 years or 36,000 miles for 2005-07 models and 5 years or 60,000 miles for 2008-10 models
- Cooling System Upgrade Kit relocates the thermostat from the cold side of the radiator to the hot side for improved cooling
- Hardware Kit included new intake gaskets and necessary hardware



Application	Part No.
Complete Supercharger Kit for 2005-09 Mustang 4.6L	1580
Complete Supercharger Kit for 2010 Mustang 4.6L	1582
Complete Supercharger Kit for 2011-12 Mustang GT 5.0L 4V	1588
Cooling System Upgrade Kit for 2005-06 Mustang GT	15804
Hardware Kit for 2009 Mustang GT	15805



Superchargers

SUPERCHARGERS

- Standard 3-year supercharger limited warranty
- Most street systems are 50-state emission legal
- Fuel management-calibration included/OBD-II computer compatibility
- Designed for maximum performance at safe boost levels on stock engines
- Optional supercharger upgrades available to achieve 30+PSI
- True OEM-quality fit and finish, made to fit under the factory hood
- Excellent technical support from factory trained, knowledgeable, and enthusiastic personnel
- Easy-to-understand installation instructions
- 100% complete, even down to the wire ties, making installation trouble free

2011 Ford Mustang GT 5.0L

Part No. FQ218024L

Type: V-3 Si-Trim High-Output

Stock HP/TQ: 405/385

Vortech HP/TQ: 605/473

Boost (PSIG): 8

CARB E.O.: In Process



05-06 Ford Mustang GT 4.6L

Part No. FU218020SQ

Type: V-2 SQ S-Trim High-Output

Stock HP/TQ: 300/320

Vortech HP/TQ: 462/419

Boost (PSIG): 9-10

CARB E.O.: D-213-25



TODAY'S PERFORMANCE

5.0L Mustang SSI Intake Manifold

- Unique equal runners deliver more horsepower and torque
- Fits all 86-93 5.0L street applications
- Includes high-flow billet Aluminum fuel rails
- Available with 70mm Throttle Body

Part No. 5001 - 86-93 SSI Series 5.0L Intake Manifold Kit

Part No. 5002 - 86-93 SSI Series 5.0L Intake Manifold Kit & 70mm Throttle Body



BOLT-ON
18-20
HORSEPOWER

Hi-Flow 96-04 4.6L Mustang 78mm Throttle Intake

One-piece design features 78mm throttle opening with high-flow Inlet Plenum.

Part No. 1780 - 96-04 Mustang GT Throttle Intake-Charcoal

Part No. 17800 - 96-04 Mustang GT Throttle Intake-Polished



NEW



Nitrous Systems

05-10 Mustang GT EFI Wet Nitrous System

- A complete wet nitrous system that fits the new Mustang GT perfectly!
- Includes all of the special parts needed for an easy, 2 hour installation
- Also features the most technically advanced performance features of any system on the market
- Patented "Active Fuel Control" that automatically adjusts nitrous fuel enrichment with bottle pressure
- Power settings are fully adjustable from 75-175 horsepower with the included tuning jets

Part No. 82034





Cap Covers

- Easy install
- Slides over stock cap
- Polished aluminum finish
- Customize your engine compartment in minutes



Part No. 6711G — Radiator Cap Cover: 05-11 Ford Mustang
Part No. 6713G — Oil Cap Cover: 05-11 Ford Mustang
Part No. 6714G — Power Steering Cap Cover: 05-10 Ford Mustang
Part No. 6716G — Brake Fluid Cap Cover: 05-11 Ford Mustang

Fuse Box Cover

- Easy install
- Slides over stock fuse box cover
- Polished aluminum finish

Part No. 6712G — Fuse Box Cover: 05-11 Ford Mustang



Door Sill Plates

- Sold as a set of 2
- Easy install
- Black anodized finish
- Protect your door sills from scratches and scuffs

Part No. 6717G — Door Sill Plates: 05-11 Ford Mustang



Lower Control Arms

- Double-adjustable design allows for on-car adjustment
- Greasable polyurethane bushing
- Constructed from high-strength tubular steel
- Durable powder-coated finish

Part No. 20105 — Adjustable: Rear Lower Control Arms: 05-11 Ford Mustang



Upper Control Arms

- Double-adjustable design allows for on-car adjustment
- Allows quick and simple pinion angle adjustment, a must for lowered vehicles
- Greasable polyurethane bushings
- Constructed from high-strength tubular steel
- Durable powder-coated finish

Part No. 20705 — Adjustable: Rear Upper Control Arms: 05-11 Ford Mustang



Panhard Rod

- Double-adjustable design allows for on-car adjustment
- Greasable polyurethane bushings
- Constructed from high-strength tubular steel
- Durable powder-coated finish

Part No. 20405 — Panhard Rod: 05-10 Ford Mustang



Strut Tower Brace

- Reduces flex between strut towers by strengthening unibody
- Simple installation with basic hand tools in less than one hour
- Clears factory and most aftermarket engine dress-up covers
- Fabricated from square mild steel tubing
- Powder-coated for durability
- Made in the USA

Part No. 39002 — Strut Tower Brace: 05-11 Ford Mustang GT, GTH, Shelby, and Bullitt



Ultra-Seal Exhaust Gaskets

- Manufactured from high-temperature graphite facing/steel core exhaust material
- Graphite facing provides excellent heat resistance and thermal conductivity to transfer heat away from cylinder head
- Conforms to and seals minor surface irregularities

Part No. 7559 — Exhaust Gasket: Ford 4.6/5.4L SOHC

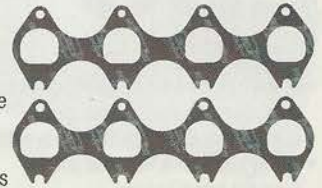

Differential Rear End Gasket

- Manufactured from high-temperature cellulose/nitrile gasket material
- Delivers excellent sealing properties for oil and gear lube applications
- Conforms to and seals minor surface irregularities

Part No. 142 — Rear End Cover Gasket: Ford 8.8"



Oil Pan Gaskets

- Manufactured from high-temperature silicone blend rubber
- Incorporates torque limiters to prevent over-torque of fasteners and gasket splitting
- Provides excellent sealing and durability

Part No. 8686G — 05-Up Ford Mustang 4.6L, 5-Speed Automatic Trans. 5R555
Part No. 6684 — 91-10 Ford 4.6L & 5.4L DOHC, Manual Trans.



Subframe Connector

- Constructed from DOM mild steel tubing
- Powder-coated for durability
- Complete with necessary mount hardware for easy installation
- Integrated triangulated torque box brace

Part No. 30201 — Subframe Connectors: 05-11 Ford Mustang



Control Arm Relocation Brackets

- Fabricated steel brackets
- Weld-on installation
- 4 mount locations for the rear lower control arms
- Improve 60' times
- Made in the USA
- Powder-coated for corrosion resistance

Part No. 20101 — Control Arm Relocation Brackets: 05-11 Ford Mustang



Rear Sway Bar End Links

- New billet aluminum end links
- Eliminate the flex inherent in the OE design
- Improved stability under load
- Bolt in place with included hardware

Part No. 19101 — Rear Sway Bar End Links: 05-11 Ford Mustang



BRAKES

EBC BRAKES

Performance Brake Pads Redstuff

- Kevlar® fiber-based brake compound enhanced with ceramic particles
- Lasts longer, brakes better, and is quieter
- A truly impressive fast road pad for repeated heavy braking
- Emits far less dust than semi-metallic pads



Front Part No.	Rear Part No.	Application
DP31143C	DP31156C	96-98 Mustang 4.6L
DP31242C	DP31156C	99-03 Mustang 4.6L
DP31242C	DP311562C	2004 Mustang 4.6L
DP31131C	DP311562C	94-04 Mustang Cobra/Bullitt 4.6L
DP31740C	DP31741C	05-11 Mustang 4.0/4.6L
DP31210C	DP31741C	07-12 Mustang GT500 5.4L

Performance Brake Pads Greenstuff

Premium street sport pad for general spirited street driving.

Greenstuff has a high initial brake effect and gives drivers confidence from first application of the brake pedal. There is no such thing as a NO DUST pad.

The very nature of how a brake works requires that some dust be generated to avoid rotor vibration (shimmying).

The EBC pad creates less dust, and dust is more easily washed off than most. For heavier, faster cars and vehicles above 200bhp, we strongly recommend Redstuff, which DOES offer much less dust.



DP2000 Series

Front Part No.	Rear Part No.	Application
DP21143	DP21156	96-98 Mustang 4.6L
DP21242	DP21156	99-03 Mustang 4.6L
DP21242	—	2004 Mustang 4.6L
DP21131	—	94-04 Mustang Cobra/Bullitt 4.6L
DP21740	DP21741	05-11 Mustang 4.0/4.6L
DP21210	DP21741	07-12 Mustang GT500 5.4L

MGP CALIPER COVERS



NEW

- Enhance your wheel appearance
- Protects the wheels from brake dust
- Easy installation, less than 10 minutes
- 6061-T6 aerospace aluminum
- CNC precision engraving for customization
- Hydraulically formed to fit each caliper
- Powder coating and custom paint match

Part No.	Application
10197SMGTB	05-10 Mustang S197- Black, Mustang on front, GT on rear, fits wheels 17" and up
10197SMGTR	05-10 Mustang S197- Red, Mustang on front, GT on rear, fits wheels 17" and up



HAWK PERFORMANCE

HPS

This unique Ferro-Carbon compound offers a higher coefficient of friction over stock brake pads and can provide you 20-40% more stopping power and higher resistance to brake fade than standard replacement pads.



HP Plus

Autocross & "Track Day" Compound

Recommended for Autocross, Solo II, and "track day" applications. HP Plus is a high-tech Ferro-Carbon friction material that was developed and manufactured for sport driving in Autocross, Solo II and "track day" applications. The formulation offers lower wear rates and higher torque values than competitive materials.

- Extremely high friction output
- Fade resistant
- Worthy for Autocross and club racing event

Product Code: N



Front Part No.	Rear Part No.	Application
HB453_585	HB485_656	2011 Mustang GT, High Performance
HB484_670	HB485_656	05-11 Mustang GT
HB274_610	HB183_660	94-04 Mustang
HB111_610	HB183_585	99-04 Mustang Cobra

When ordering, replace _ in part number with "F" for HPS or "N" for HP Plus.

POWER SLOT



Performance Brake Rotors

Power Slot rotors are CNC machined to application-specific tolerances and utilize an exclusive "vac-u-slot" that preserves outer edge rotor strength while aggressively forcing brake dust, out-gassing, and heat to vent. Developed to beat the challenges of high-performance driving and severe-duty brake demands, Power Slot rotors run cooler, extend brake life, and significantly improve wet and dry brake performance.

Left Part No.	Right Part No.	Application
12661041SL	12661041SR	94-04 Ford Mustang, Front
12661042SL	12661042SR	94-04 Ford Mustang, Rear
12661044SL	12661044SR	94-04 Ford Mustang Cobra, Front
12661046SL	12661046SR	94-04 Ford Mustang Cobra, Rear
12661086SL	12661086SR	05-12 Ford Mustang GT, Front
12661087SL	12661087SR	05-12 Ford Mustang GT, Rear



Centerforce Dual Friction®

- Patented processes to provide a performance clutch that offers exceptional street characteristics
- Outstanding holding capacity and durability
- Full facing on the pressure plate side for drivability
- Carbon composite puc style (segmented) on the flywheel side for a positive engagement
- The ultimate in street/strip holding power and performance without sacrificing pedal effort and driver control



Part No.	Application
DF023500	2011 Mustang GT 6.0L 6-Speed
DF611679	05-10 Mustang GT 4.6L
DF80075	01-04 Mustang GT 4.6L



Pro Ripper Shifter

- CNC-machined stainless steel stick assembly
- Fully adjustable stick design
- Stainless steel collar
- Spherical glass filled nylon pivot ball
- Transmission fill plug in base



Part No. 45070 — Ford Mustang 83-04 with T5 w/O.D. & T45 transmission



Billet/Plus™ Shifters

This shifter is designed to provide a more positive and secure feel when shifting and incorporates a high-ratio pivot mechanism for approximately 30% reduced knob travel, resulting in shorter, quicker shifts.

Part No.	Application	Style
3910201	05-10 Mustang GT 4.6L	Chrome
3910204	2011 Mustang GT 5.0L	Chrome



Domestic Performance Clutches



Stage 1 - 2200 Brass Plus

The CCI 2200 Brass Plus performance kit is designed for the moderate enthusiast who requires a unit superior to stock replacement. This kit will deliver an estimated 20-40% increase in torque capacity. This unit uses the CCI Brass Plus with Steel Back Facings. We have found through extensive research and development that this material clearly leads the industry in coefficient of friction, burst strength, and heat dissipation. These facings are riveted to an exclusive CCI extreme torque dampened performance disc that incorporates eight heavy-duty springs with reinforced retainer rivets.



Aluminum Flywheels

- 6061-T6 Aluminum
- 1050 High carbon steel friction surface
- 1050 Steel ring gear
- CNC machined
- Aerospace fasteners
- Many applications SFI approved

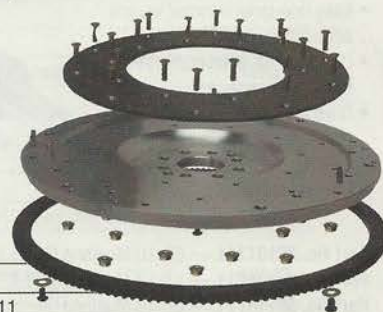

Part No.	Application
186051	Ford Mustang GT 5.0L 2011
186501	Ford Mustang 5.0L 86-95
186481	Ford Mustang 4.6L 8-bolt 96-04
186461	Ford Mustang 4.6L 8-bolt 96-04
186551	Ford Mustang GT 4.6L 6-bolt 05-10

Performance Delivered!



Auburn Gear Ected Max™ Advantages

- Switch ON/Off at any road speed
- No compressors, switch forks or pins to line up
- Smooth, quiet operation
- 9310 gear material
- Front or rear applications



Auburn Limited-Slip Differential Advantages



- Robust cone clutch—outlasts and outperforms the competition
- High strength bevel gearing—greater resistance to shock loading
- Torque sensing and biasing at ANY speed
- Quicker torque transfer under all driving conditions



SUSPENSION



Eibach® SPRINGS

Pro-Street-S

Coilovers - Adjustable Ride Height
The Next Level of Suspension Performance

- Easy ride-height/corner weight adjustability-lowering
- Designed for maximum street and track performance
- Rust-free stainless steel technology for ease of adjustment - year after year
- One-year warranty



Part No. 35101711 — 05-10 Mustang GT (F: 1.2"-2.3" / R: 1.4"-2.1")
Part No. 35125711 — 11-12 Mustang (F: 1.0"-2.4" / R: 1.0"-2.4")
Part No. 35115711 — 07-10 Mustang Shelby GT500 (F: 1.2"-2.3" / R: 1.4"-2.1")
Part No. 35128711 — 2011 Mustang Shelby GT500 (F: 1.0"-2.4" / R: 1.0"-2.4")

Pro-Plus

Performance Handling Package

- Matched performance pro-kit springs and sway bars equals superior handling for the serious enthusiast
- Precise turn-in response, improved handling and enhanced cornering grip - in any performance-driving situation



Year	Model	Lowering Front/Rear (in)	Anti Roll Front/Rear (in)	Pro-Plus Pro-Kit+Anti-Roll Kit Part No.
05-10	Mustang Coupe, V8	1.4 - 1.5	35/22	35101880
11-12	Mustang Coupe, 5.0L V8	1.0 - 1.5	36/25	35125880
07-10	Shelby GT500, Coupe, 5.4L V8 Supercharged	1.5 - 1.7	35/24	35115880
2011	Shelby GT500, Coupe, 5.4L V8 Supercharged	I/D - I/D	36/25	35128880

Pro-Kit

Performance Springs
The First Step in Performance Suspension

- High-performance handling and aggressive good looks
- Lower center of gravity - stop quicker and corner faster
- Progressive spring design for excellent ride quality



Year	Model	Lowering Front/Rear (in)	Part No.
05-10	Mustang Coupe, V8	1.4 - 1.5	35101140
11-12	Mustang Coupe, 5.0L V8	1.0 - 1.5	35125140
07-10	Shelby GT500, Coupe, 5.4L V8 Supercharged	1.5 - 1.7	35115140
2011	Shelby GT500, Coupe, 5.4L V8 Supercharged	I/D - I/D	35128140



Variant 1 Coilovers - Perfect Street Performance

- Sporty Handling with factory pre-set damping
- The ideal system for customers wishing to rely on the experience of our engineers to set the damper setting, yet determine their own degree of lowering



Part No. 10230045 — 05-11 Mustang (F: 1.2" to 2.3"/R: 1.4" to 2.1")

ENERGY SUSPENSION
Performance POLYURETHANE Components

Control Arm Bushing Sets

- Better caster and camber are maintained under hard cornering/driving
- Controls wheel hp on hard accelerations
- Increases cornering control



Part No. 43165G — Front End Control Arm Bushing Set: 05-07 Ford Mustang, Black
Part No. 43167G — Rear End Control Arm Bushing Set: 05-07 Ford Mustang, Black



S2

S2 Sport Springs

Engineered to improve handling while maintaining safety and ride quality

Part No. 261142 — 05-11 Mustang GT

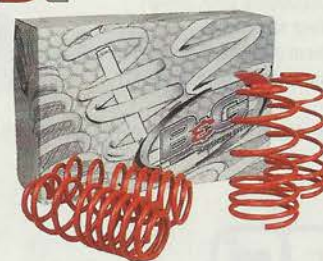

Drag Shocks

- 90/10 front shocks for maximum weight transfer
- 70/30 front shocks for street/strip
- Twin tube body
- Chrome plated piston rod
- Multi-stage valving

Part No.	Application
40517	Front 90/10 Drag Shocks 2005-2011 Mustang
40531	Front 70/30 Drag Shocks 2005-2011 Mustang
40532	Rear 50/50 Drag Shocks 2005-2011 Mustang



WHEELS/TIRES

ASK TO SEE THE COMPLETE 2012 WHEEL CATALOG FOR MORE STYLES AND FINISHES

Classic Or Modern Look - Wheels For Every Mustang

Classic styles that always look good!



Torq Thrust D
VN105D Series
(D = will clear disc brakes)
Gray Paint/Machined Lip.
15"



S188 Mustang Black
Black
18"



Mustang GT
K178 Series
Black/Brushed
17"



Klassic
32 Series
Chrome
15"



Cobra R
R189 Series
Silver
18"



AR105
105M Series
Chrome, Black/Machined, Anthracite
17/18/20/22"



Torq Thrust II
VN505/515 Series
Polished
14/15/16/17/18/20"



S/S
610 Series
Chrome, Black
15/17/18/20"

Custom offsets available upon request.



AR894
894 Series
Gloss Black Machined
18/20"



Wolverine
122 Series
Chrome, Black w/Diamond Cut
17/18/20"



Arctic
404 Series
Silver, Black
19"



518
518 Series
Black, Machined
15/16/17/18/19"

The new look for Mustang wheels



Nova
VN701 Series
Black, Gray/Machined
17/18/20"



WL035
WL035 Series
Gloss Black/Machined, PVD
18/20/22"



Daytona
VN801 Series
Black, Chrome, Gray
17/18/20"



Americana II
AR Series
Black/Machined, Graphite/Machined
18/20/22"



Rockstar
775 Series
Matte Black
17/18/20/22"



VN805
VN805 Series
Chrome, Black/Machined
18/20/22/24/26"



Phantom
882 Series
Matte Black
17/18/20"



LSS-10 - RWD
LSS Series
Machined Black/Black Lip
Machined Black/ Chrome Lip
20/22"



WL027
WL027 Series
Chrome with Black Windows
19/20/22"



DI37 Karat
37 Series
Matte Black/Machined
17/18/20"



Hurst
MUTL Series
Shadow Chrome Polished
w/Matte Gunmetal Gray Inserts
20"



MR118
MR118 Series
Matte Black
17/18"



Hustler
431 Series
Diamond Cut w/Black,
Chrome, Gray
17/18/20"



Saber
291/292 Series
Chrome/Black
16/17/18/20"

Street or strip - performance tires to give you grip



Sportsman®
S/T Radial
Raised Whites!



TOYO TIRES
driven to perform™
PROXES TR



ET Drag®
Race Slicks



TOYO TIRES
driven to perform™
PROXES TR



Sportsman®
S/R Radial
H-Rated



TOYO TIRES
driven to perform™
PROXES ST



ET Street



NEUTON
PERFORMANCE IN MOTION™
TYRES

Don't settle for factory tires - even for daily drivers



MAXXIS
MA-T1
Escapade
Premium Touring



MAXXIS
MA-V1
High Performance Radial



MAXXIS
MA-P1
Performance Touring



TOYO TIRES
driven to perform™
PROXES 4



MAXXIS
MA-Z1
Victra Z1



TOYO TIRES
driven to perform™
PROXES T1 Sport
Ultra High-Performance
Summer Tire



MAXXIS
MA-Z4S
Victra Z4S
All Season High
Performance Radial



NEW

CHEVY CAMARO



What's Inside!

Air Intake: Super Chargers, Intake Manifold, Throttle Bodies, Intake Kits.	Page 15
Exhaust: SS Performance Exhaust Systems, SS Exhaust Systems, Exhaust Systems, Muscle Car Exhaust, Performance Mufflers, Headers, Full-Length Header Systems.	Pages 16-17
Ignition: Replacement Coils, Intune, VIVID, Max Energy, Tachometers, Sport ST Gauges, 8mm Spiro-Pro Ignition Wires.	Page 18
Engine: Crate Engines, Rotating Assemblies, Pistons, H-Beam, Connecting Rods, Rocker Arms, Exhaust Manifold Bolts, Engine Bearings, Head Gaskets, Timing Sets, Valves, Hydraulic Roller Cams, Harmonic Dampers, Aluminum Harmonic Balancers, Oil Pumps, Oil Pans, Fuel Rail Kits, EFI, Thermostats For LS1, Water Pump.	Pages 19, 21, 21
Mr. Gasket: Cap Covers, Fuse Box Cover, Door Sill Plates, Rear Trailing Arms, Toe Links, Strut Tower Brace, Subframe Connector, Oil Pan Gaskets, Differential, Rear End Gasket.	Page 22
Brakes: Brake Pads, Brake Rotors, Caliper Covers.	Page 23
Drivetrain: Dual Friction Clutches, Modern Muscle Roll/Control Kit, Max-Gear Oil, Shifters, Ring & Pinions, 10-11 Camaro SS Track Pack, Sway Bar Sets.	Page 24
Suspension: Suspension Kits, Coilovers, Performance Suspension Bushings.	Page 25
Wheels: Classic Styles, New Looks, Performance Tires.	Page 26



AIR INTAKE



05-12 Corvette & 10-12 Camaro SS

- Bolt-on installation – no cutting or modification needed and fits under the stock hood and cowl
- Features Eaton® TVS Rotor assembly, the same high-quality rotors used by GM on the Corvette ZR1
- Self-contained oil system with 100,000 mile service interval (no drilling or plumbing required)
- Electronic PCM programming module with application specific tuning
- High Flow Mass Air Flow Sensor (MAFS) on some applications
- Integrated bypass valve for little to no decrease in fuel economy
- 50-state emissions street legal - E.O. numbers pending
- Available with an optional supplemental warranty



Part No.	Complete Supercharger Kit for
1593	554 HP 05-07 Corvette (LS2)
1594	599 HP 05-07 Corvette (LS2)
1590†	554 HP 08-11 Corvette (LS3)
1591†	599 HP 08-11 Corvette (LS3)
1574¥	554 HP 10-11 Corvette GS (LS3)
1575¥	599 HP 08-11 Corvette GS (LS3)
1572	657 HP 06-11 Corvette Z06 (LS7)
1597	599 HP 10-11 Camaro SS (auto)
1598	599 HP 10-11 Camaro SS (man.)

† This supercharger is NOT compatible for Z06 or ZR1 models but can be installed on dry sump equipped Grand Sport models with Edelbrock Dry Sump Accessory Kit #15905 sold separately.
 ¥ With dry sump



Power-Plus Series™ Performance Throttle Bodies

BBK is the #1 manufacturer of performance throttle bodies in the world. All units feature high-quality CNC castings with precision hardware and factory-style direct-fit linkages. Direct bolt-on horsepower and throttle response in minutes with simple hand tools.



Part No.	Application
1708	97-04 LS1 Corvette 80mm Throttle Body & Adapter Kit
1709	98-02 80mm Throttle Body - Camaro/Firebird LS1/LS6
17090	98-02 85mm Throttle Body - Camaro/Firebird LS1/LS6

LSXR™ 102mm Intake Manifold



Constructed from the same advanced polymer material as the original FAST™ LSX™ 92mm Intake Manifold, the LSXR™ offers a host of benefits over aluminum aftermarket intakes, including lighter weight, increased strength and improved heat dissipating characteristics. Other features include integrated nitrous bungs and perfect bolt-on fitment that allows the use of factory accessories without modification or clearance concerns.

- Part No. 146102—LS3 Car
- Part No. 146202—LS7 Car
- Part No. 146302—LS1/LS2/LS6 Car



Performer RPM LS1 Manifold

- Designed for the popular Chevrolet LS1 (5.7L) small-block V8 originally used in 1997 and later Corvettes and 1998-02 Camaros and Firebirds
- Also fits the Corvette LS6 engine and any other Gen III engine
- Allows the use of a carburetor on these originally computer-controlled engines
- A special throttle and trans bracket that works with 700R-4, 200R-4 and Turbo 350 transmissions is included

Part No. 7118—Performer RPM LS1 with Timing Control Module



Typhoon Manifolds

- This unique design features a larger plenum volume than stock or aftermarket manifolds
- This larger volume is particularly suited to big inch engines but extensive dyno testing on a stock LS1 also shows substantial gains

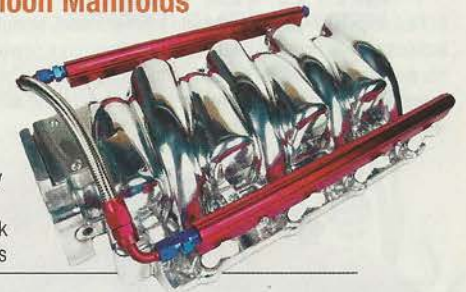

Polished	Satin		
Part No.	Part No.	RPM	Application
52060	52061	1,500-6,500	GM LS1/LS6 w/85mm inlet
52062	52063	1,500-6,500	GM LS2 w/101mm inlet



FIPK Intake Kits

- Guaranteed to increase horsepower and come with a Million Mile Limited Warranty
- Designed to dramatically reduce intake restriction as it smooths and straightens air flow
- More usable power and acceleration throughout the engine's RPM range
- Filter is washable and reusable



Part No.	Application	Engine	HP
5730222	98-02 Camaro	5.7L	+14.74hp
573052	05-07 Corvette	6.0L	+10.0hp
633074	11-12 Camaro	6.2L	+18.62hp
633073	08-12 Corvette	6.2L	+17.72hp

EXHAUST

MAGNAFLOW Exhaust PRODUCTS

SS Performance Exhaust Systems

- Mandrel-bent stainless steel tubing
- Polished, fully adjustable stainless steel tips
- Straight-through stainless steel Magnaflow Performance Mufflers



Cat-Back Part No.	Axle-Back Part No.	Application
Camaro (New Style)		
16579	16581	10-12 6.2L, Street Series, Dual Split Rear
16580	16582	10-12 6.2L, Competition Series, Dual Split Rear, 2.5"
16483	—	10-12 6.2L, Competition Series, Dual Split Rear, 3"
16583	16584	10-12 3.6L, Street Series, Dual Split Rear
Camaro (F-Body)		
16723	—	98-02 5.7L V-8, Z28/SS, Quad Tip Dual Rear Exit
15684	—	98-02 5.7L V-8, Z28/SS, Dual Rear Exit
15693	—	98-02 3.8L V-6, Dual Rear Exit

Cat-Back Part No.	Axle-Back Part No.	Application
Corvette (C5)		
15660*	15713	97-04 5.7L V-8, LS-1/LS-6, Quad Tip Exit
Corvette (C6)		
16495	—	06-12 7.0L Z06/09-12 6.2L ZR-1, Street Series, Quad Tips
16839	—	06-12 7.0L Z06/09-12 6.2L ZR-1, Magnapack, Quad Tips
15884*	15886	05-11 6.0L/6.2L V-8, LS-2/LS-3, Quad Tip Exit

*Includes Tru-X

BORLA[®] EXHAUST

SS Exhaust Systems

BORLA uses high-quality austenitic stainless steel, straight-through muffler design technology and mandrel bent pipes to deliver more power and torque, longer engine life and fuel economy. BORLA's fine motorsport styling, precision fit and distinctive Sound of Power have been recognized by racers and automotive enthusiasts worldwide for nearly 30 years.



Part No.	Application	Type	Tip Style
11775	10-12 Chevy Camaro 6.2L "S-Type"	Axle-Back	S RD RL AC
140281	10-12 Chevy Camaro 6.2L "S-Type"	Cat-Back	S RD RL AC
11788	10-12 Chevy Camaro 6.2L "ATAK"	Axle-Back	S RD RL AC
140356	10-12 Chevy Camaro 6.2L "ATAK"	Cat-Back	S RD RL AC
11774	10-12 Chevy Camaro 6.2L	Axle Back	S RD RL AC
140280	10-12 Chevy Camaro 6.2L	Cat-Back	S RD RL AC
14780	98-02 Chevy Camaro 5.7L V8	Cat-Back	D SQ AC IC
11744	05-08 Chevy Corvette C6	Rear Section	D RD RL AC
140128	05-08 Chevy Corvette C6	S-Type	D RD RL AC
140131	05-08 Chevy Corvette C6	S-Type	D OV RL AC
140292	09-11 Chevy Corvette C6	S-Type	D RD RL AC
140191	06-09 Chevy Corvette Z06	S-Type	D RD RL AC IC

CORSA[®] PERFORMANCE EXHAUSTS

Exhaust Systems

Our straight-through design coupled with RSC™ noise cancellation technology allows us to tune out the undesirable low frequencies that cause droning, while reducing back pressure. A reduction in backpressure allows the engine to produce more horsepower and torque.



What makes CORSA different?

More Horsepower • Great Sound • No Drone • Better Fuel

Part No.	Application
Touring	
14143	98-02 Camaro Z28 & SS Dual Rear Exit w/ Twin Pro-Series 3.5" Tips
14148	98-02 Camaro Z28 & Dual Rear Exit w/ Single Pro-Series 4.0" Tips
14113	09-12 Corvette C6, Twin 3.5" Pro-Series Tips
14170	05-08 Corvette C6, Touring, Dual Pro Series 3.5" Tips
Sport	
14951	10-12 Camaro 6.2L LS3 Manual, w/XO pipe & dual rear tips
14952	10-12 Camaro 6.2L L99 Auto., w/XO pipe & dual rear tips
14956	10-11 Camaro 3.6L V6, w/XO pipe & dual rear tips
14108	09-12 Corvette C6, Twin 3.5" Pro-Series Tips
14169	05-08 Corvette C6, Dual Pro Series 3.5" Tips
14164	06-12 Corvette C6 Z06, Twin Pro-Series 4" Tips

EXHAUST



Exhaust Systems

- All CNC mandrel-bent 16-gauge aluminized steel tubing
- Fully MIG-welded 16-gauge aluminized steel performance muffler(s)
- All necessary clamps, hangers and mounting hardware



Part No.	Application
817481	2011 Camaro 6.2L, Dual Rear Exit
817487	2011 Camaro 6.2L, Dual Rear Exit w/OE ground effects
17358	98-02 Camaro/Firebird, V6, 3" SS Angle Tips
17199	98-02 Camaro/Firebird, V8 LS-1, Single 3" System, 3" SS Tips
817512	05-08 Chevy Corvette C6, 3.5" Double Walled SS Quad Tips



80 Series Performance Mufflers



For True Dual performance in the space of a single exhaust system, the 80 Series™ Cross-Flow muffler is designed for transversely mounted mufflers behind the rear axle. With single or dual inlets, the 80 Series™ gives excellent ground clearance, aggressive tone, and dual outlets for your classic muscle car.

Part No.	Application
53083	98-02 Chevy Camaro/Pontiac Firebird V8
42583	98-02 Chevy Camaro/Pontiac Firebird V6
525802L	97-04 Corvette C5, Oval Tips, Left Side
525802R	97-04 Corvette C5, Oval Tips, Right Side



Hush Thrush™ Super Turbo™ Mufflers

- That vintage sound you love with the performance you expect
- The improved tri-flow design enhances flow and performance
- All mufflers are reversible for maximum installation and flexibility
- The perfect choice for that classic hot rod and today's muscle car

Part No.	Description
17631	2.25" In/Out, Offset/Center
17632	2.25" In/Out, Offset/Offset
17633	2.5" In/Out, Offset/Center
17634	2.5" In/Out, Offset/Offset
17635	3" In/Out, Offset/Center
17636	3" In/Out, Offset/Offset



Thrush

More Applications Available



Muscle Car Exhaust

- Lifetime Warranty
- True muscle car sound
- Stainless steel construction

PRO Part No.	XP Part No.	Application
S7020304	S7020409	10-11 Camaro, V6 3.6L, Dual Cat Back, Round Tips
S7018304	S7018409	10-11 Camaro, V8 6.2L 6 Speed, Dual Cat Back, Round Tips
S7022304	S7022409	10-11 Camaro, V8 6.2L 6 Speed, Dual Cat Back, Rectangle Tips
S7024304	S7024409	10-11 Camaro, V8 6.2L Automatic (L99)
S7026304	S7026409	10-11 Camaro, V8 6.2L Automatic (L99) w/ Ground Effects Pkg



Quik Trip Headers

All PaceSetter headers have 3/8"-thick steel head flanges, port matched for best seal and flow. Tubing is 16-gauge and mandrel bent to ensure the best performance.

Painted Part No.	Armor*Coat Part No.	Application
Quik Trip Long Tube Headers		
702257	72C2257	2010 Camaro 6.2L
702232	72C2232	2010 Camaro 3.6L
702255	72C2255	00-02 Camaro/Firebird, 5.7L LS1 1-3/4"
702256	72C2256	98-02 Camaro/Firebird, 5.7L LS1 1-3/4"
701335	72C1335	94-95 Camaro/Firebird, 5.7L LT1 1-5/8"
Race (No A.I.R. or EGR)		
702253	—	98-99 Camaro/Firebird, 5.7L LS1 1-3/4"
—	72C2237	96-97 Camaro/Firebird, 5.7L LT1 1-3/4"
702235	72C2235	94-95 Camaro/Firebird, 5.7L LT1 1-3/4"

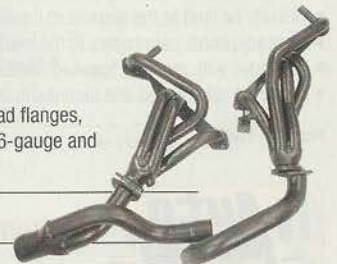

Full-Length Header Systems

Manufactured with 1-3/4" CNC mandrel-bent tubing for unrestrictive airflow and a one piece 3/8" laser-cut flange for added strength and durability. All BBK exhaust headers are pressure tested to ensure leak-free performance. All exhaust header kits include new gaskets and hardware.

Part No.	Application
1694	98-02 Chevy Camaro LS1, Ceramic
1567	94-95 Chevy Camaro LT1, Single Cat, Ceramic
1568	95-97 Chevy Camaro LT1, Dual Cat, Ceramic
4021	10-12 Chevy Camaro, Dual Cat, Ceramic
4023	10-12 Chevy Camaro, Off-Road, Ceramic



IGNITION

Blaster OEM Replacement Coils

- Fit in place of the stock Gen-III GM coils and connect directly to the factory connectors
- Higher energy sparks, crowned with MSD's multiple spark discharge
- Improved throttle response, smooth idle and quick starts, plus increased high rpm performance!

Part No. 82458—GM Gen 3 LS Series (LS1/6) Coil Kit

Part No. 82478—GM LS2/7 Series Coil Kit



- Runs a carbureted LS2 engine without complicated EFI hardware
- Map a timing curve using Pro-Data+ software
- Programmable two-step rev limiter, vacuum advance curve and step retard
- Direct plug-in to factory components
- Programmable via a PC through MSD's Pro-Data+ software



Part No. 6012—GM LS2/7, 06-On 58-Tooth Crank

DIABLOSPORT® GASOLINE AND DIESEL TUNING SYSTEMS



The DiabloSport inTune is the next generation of tuning tools, a total revolution in the tuning industry. The inTune contains innovative features not available anywhere else.

- Least expensive full color touchscreen available
- USB connectivity
- Easy to use
- Free automatic updater
- Removable cables
- External sensor inputs
- One part number for all applications, including gas and diesel
- Virtually no limit to the amount of custom tunes the inTune can hold
- Most adjustable parameters in the market
- Preloaded with multiple "canned" tunes for increased HP, TQ and MPG
- Designed, engineered and manufactured in the USA



Part No. I1000



Tachometers

Auto Meter's Original "Monster" size tachometers feature an air core meter movement and advanced electronic circuitry that provide accuracy and fast action response. The 5" or 3-3/8" dial face provides maximum readability and adjustable red line shift marker helps maintain proper shift points.



Part No. Description

233904	5" Tach w/Shift Light, 10,000 RPM, Black/Black
233906	5" Memory Tach w/Shift Light, 10,000 RPM, Black/Black
2300	3-3/8" Tach, 8000 RPM, Black/Black
2301	3-3/8" Tach, 8000 RPM, Chrome/Black



Sport ST Gauges Electrical



Part No. Description

CP7001	Oil Pressure 0-100 PSI, 90° sweep Includes electrical sender
CP7003	Transmission Fluid Temp. 100°-280°F, 90° sweep Includes electrical sender
CP7005	Water/Oil Temp. 100°-280°F, 90° sweep Includes elect. sender
CP7011	Air/Fuel Ratio 0-1.0V monitors O2 sensor; red, orange, yellow, green and blue LEDs
CP7019	Exhaust Gas Temp. 0-2000°F, 270° sweep 10 ft. thermocouple probe with compression fitting & weld-in bushing



Superchips VIVID LINQ is the only tuning device in the industry designed to work with Android™ OS smartphones. LINQ is available for nearly 1,000 vehicle applications including most popular truck, performance car, and SUVs produced in the last decade. LINQ is a Bluetooth wireless vehicle tuning interface that turns your phone into a performance tuner, diagnostic trouble code tool, PID reader, driving coach, or virtual dash board with the touch of the phone screen. Combine your Android phone with LINQ for an affordable yet advanced vehicle tuning experience!



Part No. 128650 - 99-Up GM Gas Vehicles



The World Leader In High-Performance Engine Tuning Products



Adjustable features so you can customize your vehicle exactly the way you want in just minutes.



Part No. Application

32501	10-11 Camaro 6.2L
32501	06-09 Corvette 6.0 LS2/7.0 LS7
32500	97-04 Corvette 5.7 LS1/5.7 LS6, 98-02 Camaro/Firebird 5.7 LS1

- Automatic transmission shift points & firmness
- Top-speed limiter
- RPM "rev" limiter
- Diagnostics
- Cooling fan temps
- Internet updates
- Speedometer correction for non-stock rear gears



8mm Spiro-Pro Ignition Wires

- Available for street or track applications
- Spiro-Wound with stainless steel wire
- Covered with a conductive fluorocarbon material
- Provides more fire power to the spark plugs
- Eliminates radio frequency interference
- Two layers of 100 percent pure silicone



10-11 Chevy Camaro 6.2L

Part No. 74044—Black

Part No. 74644—Blue

Part No. 74244—Red



Edelbrock RPM Xtreme LS1/LS2

Designed for 1997 and later GEN 3 & 4 LS1/LS2 small block Chevy engines, including 4.8L, 5.3L, 5.7L and 6.0L. RPM heads are CNC ported in critical areas for improved airflow and peak performance. The high-velocity intake and exhaust runners are completely CNC ported to deliver optimal airflow and velocity at all lift values for a broad range of torque and impressive peak horsepower. Fully assembled and ready to bolt on. Made in the USA. Part No. 61949

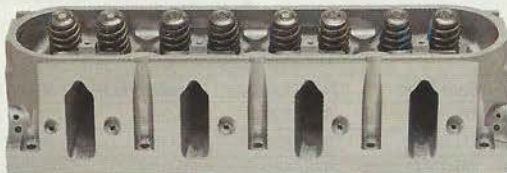

Competition Rotating Assemblies



- The perfect choice for the most demanding applications
- Premium 4340 H-Beam rods and 4340 steel crankshafts
- Premium forged pistons
- Clevis 77 race bearings and plasma moly rings
- Designed for internal balance

Part No.	Engine	Stroke	CID	Rod	Piston	Type	
12800	LS1/LS6/LSX	3.622	347	6.125	JE	Flat	Unbalanced
12804	LS1/LS6/LSX	4.000	383	6.200	Arias	Flat	Unbalanced
B12804	LS1/LS6/LSX	4.000	383	6.200	Arias	Flat	Balanced
12806	LS1/LS6/LSX	4.100	393	TBA	Arias	Flat	Unbalanced
12822030	LS2 to 05	4.000	408	6.125	Arias	Inv. Dome	Unbalanced, .030
B12822030	LS2 to 05	4.000	408	6.125	Arias	Inv. Dome	Balanced, .030
12827030	LS2 05-Up	4.000	408	6.125	Arias	Flat	Unbalanced, .030



"ESP" Forged 4340 Crankshafts

- Manufactured with a multi-stage heat treatment process
- Stress relieved, shot-peened, and nitrided
- Magnafluxed and sonic tested to ensure quality
- Lightening holes in every rod throw for weight reduction
- Designed for internal balance



Part No. 4346362261—LS1 Chevy, 3.622 Stroke, w/24 tooth reluctor wheel
 Part No. 4346400061—LS1 Chevy, 4.00 Stroke, w/24 tooth reluctor wheel
 Part No. 4346410061—LS1 Chevy, 4.10 Stroke, w/24 tooth reluctor wheel



SRP Professional Pistons

- Advanced, lightweight FSR forging that eliminates stress concentrations for superior strength
- Up to 20% lighter than traditional equivalent
- High-silicon 4032 aluminum alloy for reduced piston-to-wall clearance and quiet operation
- Accumulator grooves for improved ring seal
- Designed for normally aspirated or moderate forced induction/nitrous applications

Part No.	Bore	Stroke	Rod Length	Compression Distance	Dome Vol cc	Gram Weight	Notes
279585	4.005	4.000	6.125	1.115	-5	385	LS2/LS3/LS6/L92 - Flat top
279590	4.005	3.622	6.125	1.315	-5	417	LS2/LS3/LS6/L92 - Flat top
287994	4.000	3.622	6.125	1.340	-14	429	LS2/LS3/LS6/L92 - Inverted dome .945 pin
288003	4.000	3.622	6.125	1.315	-14.3	427	LS2/LS3/LS6/L92 - Inverted dome .927 pin
288004	4.005	3.622	6.125	1.315	-14.3	428	LS2/LS3/LS6/L92 - Inverted dome .927 pin
288005	4.030	3.622	6.125	1.315	-15.5	437	LS2/LS3/LS6/L92 - Inverted dome .927 pin



LS3 E-ROD Crate Engine

Introducing the first-ever emission-compliant crate engine package: the E-ROD LS3. GM engineers have harnessed world-class power and efficiency, all in one package. And with 430 HP, there's no sacrificing power for compliance. This gives you the freedom to build your project car with the confidence that it can be registered and legal. Part No. 19244805



LSX454 Crate Engine

With the LSX Bowtie block, GM Performance Parts engineers were able to build a 21st century 454 with the latest technology — and it requires no more space under the hood than a production LS engine. It's perfect as the power plant for a late-model Camaro drag car or a high-tech retro-fit for a '70 Chevelle pro-touring machine. The LSX454 is filled with an all-forged, super-tough rotating assembly and features a pair of our new, deep-breathing LSX six-bolt cylinder heads. It also comes dressed with great-looking, all-new orange powder-coated valve covers with engraved "LSX454" logos. GMPP delivers the LSX454 without an intake manifold and other accessories. With a carburetor and high-flow GM Performance Parts intake manifold, the LSX454 is good for about 620 horsepower and 600 lb-ft of torque — or about 580 hp and 600 lb-ft. with fuel injection. Part No. 19244611

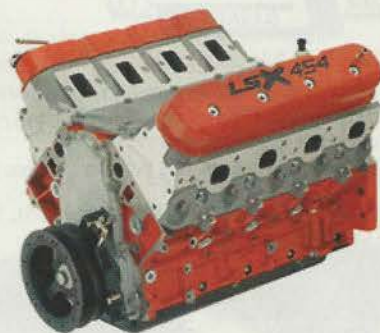

4340 Forged H-Beam Connecting Rods

- H-beam design is the strongest SCAT rod available
- Perfect for supercharged and nitrous applications
- Special doweled cap for specific cap-to-rod alignment
- Profiled clearance for stroker applications



Part No.	Application	Rod Length	Crank Pin	Wrist Pin	B.E. Width	Cap Screws
6570021	Chevy 350/LS1	5.700	2.100	.927	.940	ARP 8740 7/16"
6625021	Chevy 350/LS1	6.250	2.100	.927	.940	ARP 8740 7/16"

ENGINE



Ultra-Gold™ ARC Rocker Arms

- Revolutionary design, updates, and new features
- New arced, recessed, contoured design with channel and contoured top, similar to a bridge design, gives the rockers the best strength-to-weight ratio possible
- Improved clearances for valve covers and springs
- Manufactured entirely in the USA

Part No. 1902416 — GM Gen III/LS1/LS2/LS4/LS6, 8mm Stud, 1.72 Ratio

Part No. 1902516 — GM Gen III/LS1/LS2/LS4/LS6, 8mm Stud, 1.82 Ratio



Xtreme Fuel Injection (XFI™) Hydraulic Roller Cams

- Specifically engineered for fuel injected engines
- Wider lobe separation for decreased overlap
- Faster valve openings and closings
- Designed for optimum valve control



Part No.	Cam Type	Adv. Duration	Duration @.050"	Valve Lift	Sep. Angle
5440811	XFI RPM	.515/.522	259/265	206/212	112
5441211	XFI RPM	.522/.529	265/271	212/218	114
5441411	XFI RPM	.525/.532	269/273	216/220	114
5441611	XFI RPM	.530/.534	273/277	220/224	112
5441811	XFI RPM	.534/.537	277/281	224/228	112
5442411	XFI RPM Hi-Lift	.558/.563	265/271	212/218	115
5442611	XFI RPM Hi-Lift	.566/.568	275/277	222/224	112



Exhaust Manifold Bolts – Metric

- Designed for quick, easy installation and removal
- Compact socket head design is ideal for use where space is minimal
- Socket head bolt 8mm-1.25 x 30 mm L (16 pcs.)



Part No. 979G — Chevrolet LS2 & LS3/L99 6.2L, 2005-10

ARP Automotive Racing Products Cylinder Head Studs and Bolts

- These head bolt and head stud kits are rated at 170,000 psi
- 15% stronger than Grade 8 fasteners



Part No.	Application
Head Bolt Kits	Gen III/LS Series
1343609	Small block (2003 & earlier) hex
1343610	Small block (2004 & later) w/ all same length hex bolts
Head Stud Kits	Gen III/LS Series
2344316	Small block (2004 & later) w/ all same length studs, Hex
2344317	Small block (2004 & later) w/ all same length studs, 12 pt.



Performance Engine Bearings

We offer the most extensive line of performance engine bearings in the market. Our range of performance engine bearings is designed to provide winning results even in the most demanding applications. Our involvement in INDY, NASCAR, ARCA, NHRA, and IHRA racing as well as other forms of motorsports has proven Clevite to be the leaders in engine bearing technology both on the track and off.



Part No.	Description
Race Coated Main Bearings	
MS2199HK	Race Series TM77, GM LS Series, Grooved Upper, Coated, Standard
MS2199HK1	Race Series TM77, GM LS Series, Grooved Upper, Coated, .001 Undersize
MS2199HK10	Race Series TM77, GM LS Series, Grooved Upper, Coated, .010 Undersize
OE Type Rod Bearings	
CB663P	Standard Series OE Replacement, Chevy 305/350, Standard
CB663P1	Standard Series OE Replacement, Chevy 305/350, .001 undersize
CB663P10	Standard Series OE Replacement, Chevy Small Block, .010 undersize
CB663P20	Standard Series OE Replacement, Chevy 305/350, .020 undersize
CB663P30	Standard Series OE Replacement, Chevy Small Block, .030 undersize
Cam Bearings	
SH1814S	Chevy LS Series Engines 97-03



Severe Duty/Pro-Flo Valves

- XH-428 stainless exhaust material
- Chrome stems and hard tips
- Intakes are "Pro Flo" for improved flow
- NK-844 stainless intake material
- Swirl polished and machined
- OE-style radius keeper grooves



Available for LS1, LS2/LS6 and LS3/L99 engines



True® Roller Timing Sets

- Heat-treated, billet steel sprockets
- Premium True® roller chain – tested to 650 hp
- Hand-matched at factory for accuracy



Part No. 93158A - LS1 timing set, Hex-A-Just True® Roller, single roller chain

Part No. 93159A - LS1 timing set, Hex-A-Just True® Roller, double roller chain



Head Gaskets

For 97-04 Chevy 346 (5.7L) LS1/LS6

MLS Gaskets

Made from nitrile rubber-coated stainless steel metal layers. Ideal for supercharged, turbo charged, nitrous oxide, and high compression ratio engine applications.

Ultra-Seal Gaskets

Made from five-layer composition construction, graphite core, steel outer layers and silicone coated. Ideal for bi-metal (aluminum/cast iron) OE and performance engine applications.

Part No.	Description
MLS Gaskets	
3143G	4.125" Bore, .054" Thick (pair)
3144G	4.160" Bore, .054" Thick (pair)
Ultra-Seal Gaskets	
5713G	4.00" Bore, .051" Thick (Left Side, each)
5714G	4.00" Bore, .051" Thick (Right Side, each)

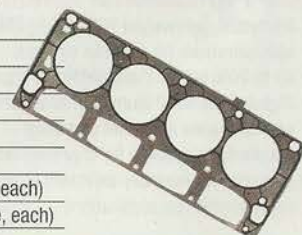
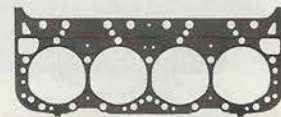

Professional Products®

Powerforce Harmonic Dampers

The Powerforce dampers are one of the best quality, low-cost performance street dampers available. They feature engraved marks at TDC and every 90° plus 60° of timing marks in easy-to-read white numbers. Made of tough nodular iron, these dampers are 30% stronger than a stock model.



Part No. 80032—LS1 Camaro/Firebird, Internally Balanced, 7.5" OD

Part No. 80033—LS1 & LS6 Corvette, Internally Balanced, 7.5" OD



Aluminum Harmonic Balancers

- Provides maximum control of destructive crankshaft vibration at all engine speeds
- Extends crankshaft and bearing life
- SFI accepted, explosion proof
- 100% Satisfaction Guaranteed / 100% American made



Part No. 720102—Chevy LS1 Camaro & Firebird, 7.25" od, 7.28 lbs, SFI, 10% Underdrive

Part No. 740111—LS1/LS2/LS6 Camaro/Firebird/GTO, 7.5", 10.5 lbs.



M-Select Race Oil Pumps

- Cast aluminum housing is CNC machined and hardcoat anodized
- Cast iron cover is CNC machined and phosphate coated
- Relief valve features a screw in valve plug with the optional lower stock pressure spring supplied
- Uses stock 1-1/4" bolt on screen



Part No. 10295—GM LS Series engines, Standard Volume, High Pressure, Gerotor, 10 extra psi

Part No. 10296—GM LS Series engines, 18% Additional Volume, Gerotor, 10 extra psi



Oil Pans

American ingenuity and integrity, since 1968.

- Designed for street-performance machines that occasionally see some track time
- Modified with either a Deep Sump or Kicked-Out Sump for increased capacity
- Designed for simple bolt-on installations in production chassis



Part No.	Application/Description
20140	GM LS1/LS6, Wet Sump, 7 Qt. Capacity, 6" Deep, Clear Zinc Plated Steel
20141	GM LS Series, Wet Sump, 7 Qt. Capacity, 6" Deep, Angled Sump, Clear Zinc Plated Steel
24050	Pickup for #20140 & #20141



High-Performance Water Pump

- These "super cooling" pumps are computer-designed to deliver more flow at a higher velocity
- Precision-cast powdered metal impellers have extra large vanes for the maximum flow rate possible, ensuring adequate pressure and volume even at lower engine speeds

Part No. 8896—Two-Piece Pump for GM Gen III & IV LS (3/4" pilot shaft)

Part No. 8898—Universal Billet aluminum water pump pulley for #8896

Professional Products®

Fuel Rail Kits

- The Basic Kit is designed for the tuner who wants to combine his own various components with basic fuel rails
- The basic kit provides fuel rails, stainless mounting brackets and stainless mounting hardware
- A stainless steel fitting is included that allows a connection to the stock fuel line
- The Complete Kit includes all the parts from the Basic Kits plus a stainless braided -06 AN fuel crossover hose, additional fittings and an adjustable fuel pressure regulator in the 10611 kit



Part No.	Application/Description
10610	Basic Kit 97-04 LS1/LS6, Rails, Brackets, Hardware, Fuel Line Adapter
10611	Complete Kit 97-98 LS, w/Crossover, Regulator & Adapter Fitting
10612	Complete Kit 99-04 LS1/LS6, w/Crossover & Adapter Fitting
10614	Complete Kit 05-07 LS2, w/Crossover & Adapter Fitting



Holley HP EFI

- Full-featured systems with full laptop tunability plus Self-tuning!
- Versatile capabilities - Control power adders and other functions!
- Intuitive software - Easy to use!
- Ideal for LSX engine swaps!
- Ideal for street, drag race, road racing, off-road and marine applications



Part No. 550602 — GM LS1

Part No. 550603 — GM LS2



Mr. Gasket Thermostats For LS1

Available for all new style Chevy LS series automobile and L series truck motors that utilize a separate thermostat and water neck. These thermostats are available in 160, 180 and 195 degree temperatures to suit any application.



Part No. 6367—LS1 late thermostat 160°

Part No. 6368—LS1 late thermostat 180°

Part No. 6369—LS1 late thermostat 195°

CAMARO



Cap Covers

- Easy install
- Slides over stock cap
- Polished aluminum finish
- Customize your engine compartment in minutes

Part No. 6701G—Radiator Cap Cover: 10-11 Chevy Camaro SS
Part No. 6703G—Oil Cap Cover: 10-11 Chevy Camaro SS
Part No. 6706G—Brake Fluid Cap Cover: 10-11 Chevy Camaro SS



Fuse Box Cover

- Easy install
- Slides over stock fuse box cover
- Polished aluminum finish

Part No. 6702G—Fuse Box Cover: 10-11 Chevy Camaro SS



Door Sill Plates

- Sold as a set of 2
- Easy install
- Black anodized finish
- Protect your door sills from scratches and scuffs

Part No. 6707G—10-11 Chevy Camaro SS

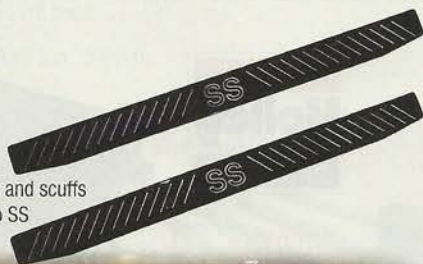

Rear Trailing Arms

- Constructed from high-grade mild steel tubing
- Full perimeter MIG welds
- Greasable polyurethane bushings
- Powder-coated black
- Designed and built in the USA

Part No. 20143—10-12 Chevy Camaro



Toe Links

- Constructed from high-grade mild steel tubing
- Full perimeter MIG welds
- Greasable polyurethane bushings
- Powder-coated black
- Designed and built in the USA

Part No. 20101—Adjustable Toe Links, 10-12 Chevy Camaro

Part No. 20102—Fixed Toe Links, 10-12 Chevy Camaro



Part No. 20102



Part No. 20101

Ultra-Seal Exhaust Gaskets

- Manufactured from high-temperature graphite facing/steel core exhaust material
- Graphite facing provides excellent heat resistance and thermal conductivity to transfer heat away from cylinder head
- Conforms to and seals minor surface irregularities



Part No. 5966—Exhaust Gasket: Chevy LS2 and LS3/L99 6.2L, 05-10

Ultra-Seal III Differential Rear End Gasket

- Made from Mr. Gasket Premium Ultra-Seal III high-tensile strength and high-temperature gasket material
- Delivers excellent sealing properties for oil, fuel, coolant, and gear lube. Conforms to and seals any imperfections on sealing surfaces
- Releases easily (no gasket scraping required), will not stick to axle housing or differential rear end cover mating surfaces
- Required when changing differential rear end gears and rear end cover



Part No. 4605G—Rear End Cover Gasket: 08-Up Chevy Camaro w/8.5" Ring Gear

Oil Pan Gaskets

- Manufactured from high-temperature silicone blend rubber (auto) or aluminum (manual)
- Incorporates torque limiters to prevent over-torque of fasteners and gasket splitting
- Provides excellent sealing and durability

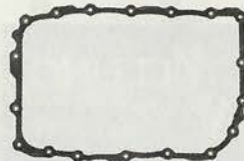

Part No. 8685G—08-Up Chevy Camaro 6.2L, 6-Speed 6L80E

Part No. 6665G—08-Up Chevy Camaro 6.2L, Manual Trans.

Subframe Connector

- Ties front and rear subframe together
- Increases chassis strength
- Reduces wheel hop
- Bolt-on or weld-in installation
- Made in the USA

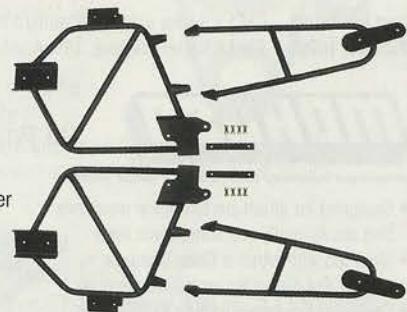

Part No. 30101—Subframe Connectors: 10-11 Chevy Camaro

Strut Tower Brace

- Reduces flex between strut towers by strengthening unibody
- Strut removal not required for installation
- Simple installation with basic hand tools in less than one hour
- Clears factory and most aftermarket engine dress-up covers
- Fabricated from square mild steel tubing
- Powder-coated for durability
- Made in the USA



Part No. 39000—Strut Tower Brace: 10-11 Chevy Camaro

EBC BRAKES

Redstuff Performance Brake Pads



- Kevlar® fiber-based brake compound enhanced with ceramic particles
- Lasts longer, brakes better, and is quieter
- A truly impressive fast road pad for repeated heavy braking
- Emits far less dust than semi-metallic pads

Front Part No.	Rear Part No.	Application
DP31210C	DP31788C	10-11 Chevy Camaro 6.2L
DP31142C	DP31167C	94-97 Chevy Camaro 5.7L
DP31239C	DP31323C	98-02 Chevy Camaro 5.7L
DP31131C	DP31167C	88-96 Corvette 5.7L
DP31162C	DP31160C	97-08 Corvette 5.7/6.0L

Greenstuff Performance Brake Pads



Premium street sport pad for general spirited street driving.

Greenstuff has a high initial brake effect and gives drivers confidence from first application of the brake pedal. There is no such thing as a NO DUST pad. The very nature of how a brake works requires that some dust be generated to avoid rotor vibration (shimmying). The EBC pad creates less dust, and dust is more easily washed off than most. For heavier, faster cars and vehicles above 200bhp, we strongly recommend Redstuff, which DOES offer much less dust.

Front Part No.	Rear Part No.	Application
DP21210	DP21788	10-11 Chevy Camaro 6.2L
DP21142	DP21167	94-97 Chevy Camaro 5.7L
DP21239	DP21323	98-02 Chevy Camaro 5.7L
DP21131	DP21167	88-96 Corvette 5.7L
DP21162	DP21160	97-08 Corvette 5.7/6.0L

HAWK PERFORMANCE

HPS Performance Street Brake Pads



This unique Ferro-Carbon compound offers a higher coefficient of friction over stock brake pads.

- Increased stopping power
- High friction/torque hot or cold
- Extended pad life
- Low dust
- Virtually noise-free

HP Plus Autocross & "Track Day" Compound

Recommended for Autocross, Solo II, and "track day" applications. HP Plus is a high-tech Ferro-Carbon friction material that was developed and manufactured for sport driving in Autocross, Solo II and "track day" applications. The formulation offers lower wear rates and higher torque values than competitive materials.



- Extremely high friction output
- Fade resistant
- Worthy for Autocross and club racing event

Product Code: N

Front Part No.	Rear Part No.	Application
HB453 585	HB194 570	10-12 Camaro 6.2L
HB249 575	HB250 653	98-02 Camaro/Firebird 5.7L
HB217 681	HB112 540	94-97 Camaro/Firebird 5.7L
HB247 575	HB248 650	97-08 Corvette C5, C6
HB531 570	HB532 570	06-08 Corvette C6 Z06

When ordering, replace space in part number with "F" for HPS or "N" for HP Plus.



MGP CALIPER COVERS



Caliper Covers

- Enhance your wheel appearance
- Protects the wheels from brake dust
- Easy installation, less than 10 minutes
- 6061-T6 aerospace aluminum
- CNC precision engraving for customization
- Hydraulically formed to fit each caliper
- Powder coating and custom paint match



Part No.	Application
13007SCVTB	97-04 Corvette C5 - Black, Fits wheels 17" and larger
13007SCVTR	97-04 Corvette C5 - Red, Fits wheels 17" and larger
13007SCVTS	97-04 Corvette C5 - Silver, Fits wheels 17" and larger
14033SCARR	10-12 Camaro RS - Red, Camaro on front, RS on rears, fits RS, V6, LS, 1LT, 2LT
14033SMGPB	10-12 Camaro RS - Black, MGP logo, Fits RS, V6, LS, 1LT, 2LT
14033SMGPR	10-12 Camaro RS - Red, MGP logo, Fits RS, V6, LS, 1LT, 2LT
14036SMGPB	10-12 Camaro SS - Black, MGP logo
14036SMGPR	10-12 Camaro SS - Red, MGP logo

POWER SLOT

Performance Brake Rotors

Developed to beat the challenges of high-performance driving and severe-duty brake demands, Power Slot rotors run cooler, extend brake life, and significantly improve wet and dry brake performance.



Left Part No.	Right Part No.	Application
12662124SL	12662124SR	11-12 Camaro 6.2L, Front
12662055SL	12662055SR	98-02 Camaro
12662059SL	12662060SR	97-04 Corvette, C5, All Incl. Z06, Front
12662061SL	12662062SR	97-04 Corvette, C5, All Incl. Z06, Rear

DRIVETRAIN



Modern Muscle Roll/Control Kit

Used primarily in drag racing to provide positive locking action to the front wheels of race cars. Field serviceable for cleaning or rebuilding. Kit includes solenoid valve, snap-action switch, indicator light, 4-amp fuse, mounting screws and installation instructions

Part No. 5671518 — 10-11 Chevy Camaro



Dual Friction Clutches

- Outstanding holding capacity and durability
- Carbon composite puc style (segmented) on the flywheel side for a positive engagement
- The ultimate in street/strip holding power and performance without sacrificing pedal effort and driver control

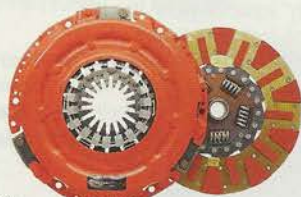

Part No. DF017010 — 98-02 Chevy Camaro 5.7L LS1

Part No. DF017010 — 97-04 Corvette C5 LS1

Part No. DF593010 — 10-11 Chevy Camaro 6.2L LS3

Fidanza

Aluminum Flywheels

- 6061-T6 Aluminum
- 1050 High carbon steel friction surface
- 1050 Steel ring gear
- CNC machined
- Aerospace fasteners
- Many applications SFI approved



Part No. Application

198171 Chevy Camaro SS 2010

198571 Chevy Camaro/Firebird 5.7L 98-02

198501 Chevy Corvette LT-1 89-96

198571 Chevy Corvette 97-04



Max-Gear Oil

Max-Gear is an ultra-tough, high performance GL-5 gear oil designed to provide maximum protection for heavily loaded gears while reducing friction. Max-Gear virtually eliminates gear and bearing wear - even under severe conditions caused by high loads or sudden shock loads. Max-Gear allows gears to run cooler, quieter, smoother and longer.

Part No. 01300 — 75W90, Quart

Part No. 01301 — 75W140, Quart

Part No. 01303 — 85W140, Quart



Comp/Stick Kits For 2010+ Camaro

Dress up your 2010+ Camaro automatic shifter!

This is the complete comp stick and plate kit, with a CNC-machined, anodized black console plate featuring dual indicator window and all the installation hardware, and the "harddrive" style stick with integrated park/reverse lock-out trigger.

Part No. 5380432



Billet/Plus 2 Shifter For 10-11 Chevy Camaro

- 2010 Chevrolet Camaro, V6 and V8
- CNC-machined stainless steel stick assembly
- Nylon-lined spherical pivot bearing
- Shift throw reduced for quicker shifts
- Smooth positive mechanism
- Bolt-on classic chrome plated stick and white knob
- CNC-machined stick adapter accepts Classic Hurst stick

Part No. 3916030



Console Megashifter

The popular Megashifter bolts directly into the stock console and retains the look and integrity of the original car but with a high-performance shifter. The console Megashifters are regular Megashifter, the console units are standard with a T-Handle, lighted indicator, and neutral safety switch.

Part No. 80692 — 82-92 Camaro/Firebird

Part No. 80694 — 73-81 Camaro/70-81 Firebird



Ring & Pinions for 10-11 Chevy Camaro

- Street gears designed specifically for the 2010 Camaro
- Engineered to perform faster and more reliably
- Matching installation kits available

Part No. 4901871 — 10-11 Camaro V8, 3.73 Ratio

Part No. 6904921 — 10-11 Camaro V8, 4.10 Ratio

Part No. 6904931 — 10-11 Camaro V8, 4.33 Ratio

Part No. 8310771 — Installation Kit, 10-11 Camaro V8



"Six Shooter™" Coupler

We solved the problem of weak OEM couplers. Made of fully machined 6061-T6 billet aluminum, featuring specially formulated urethane inserts providing NVH dampening that is not available with solid aftermarket units.



Part No. 71652 — 10-11 Camaro, Auto. (each)

Part No. 71653 — 10-11 Camaro, Manual (each)

SUSPENSION



Eibach® SPRINGS

Pro-Street-S Coilovers - Adjustable Ride Height The Next Level of Suspension Performance

- Easy ride-height/corner weight adjustability-lowering
- Designed for maximum street and track performance
- Rust-free stainless steel technology for ease of adjustment - year after year
- One-year warranty



Part No. 38144711 — 10-11 Camaro, LS, LT, SS

Pro-Kit

- High-performance handling and aggressive good looks
- Stop quicker, corner faster, and get better mpg
- Progressive spring design for excellent ride quality

Part No.	Application	Lowering	
		Front	Rear
38126510	05-12 Corvette	0-2"	0-2"
38124510	97-04 Corvette	0-2"	0-2"
38137140	08-09 Pontiac G8, 6.0L	1.0"	0.8"
38144140	10-12 Camaro SS	1.0"	1.0"
3897140	04-07 Pontiac GTO	1.0"	0.8"
3870140	98-02 Camaro/Firebird	1.2"	1.2"



Pro-Plus Performance Handling Package

- Matched performance pro-kit springs and sway bars = superior handling for the serious enthusiast
- Precise turn-in response, improved handling and enhanced cornering grip - in any performance-driving situation



Year	Model	Lowering Front-Rear (in)	Anti-Roll Front/Rear (in)	Pro-Plus Pro-Kit+Anti-Roll Kit Part No.
10-12	Camaro	1.0 / 1.0	29 / 29	38144880
10-11	Corvette C6	0-2.0 / 0-2.0	32 / 29	38126880



Variant 3 Coilovers - Perfect Street Performance

State-of-the-art technology from motor sports for more performance on the road. The separate and independently adjustable rebound and compression damping allows for an individual suspension setup for different uses and preferences. The unique patented system with its two-stage valves allows a rebound damping adjustment (comfort) and a compression adjustment (driving dynamics) in the low-speed range while the high-speed range which controls the driving safety is fixed.

Part No. 35261017 — 10-11 Camaro (F: 0.9" to 2.0" / R: 0.8" to 2.0")



Performance Suspension Bushings

Designed for the popular 10-11 Chevrolet Camaro to produce handling improvements on the street and on the track. Expect increased road awareness and a dramatic improvement in durability that can't be replicated anywhere else.

- Part No. 33195 — Front control Arm Bushing Set
- Part No. 34168 — Rear Sub frame Mount Inserts
- Part No. 34169 — Rear Sub frame Mount Replacements
- Part No. 35219 — Rear Sway Bar Bushing Set 23mm

Add "G" for Black or "R" for Red to the end of the part number.



10-11 Camaro SS Track Pack

- Tuned, Balanced System combines sport springs adjustable sway bars, and aluminum chassis bracing
- Sport Coil Springs, Front 210lbs/in, Rear 440 lbs/in, 1" Lowered Stance
- Lightweight 1.25" tubular front and 1" adjustable rear sway bars Includes greasable polyurethane bushings, and mounts
- Strong lightweight aluminum chassis brace reduces sub-frame flex and wheel hop
- Durable, gloss powder-coat finish
- Direct bolt-on installation

Part No. 80116

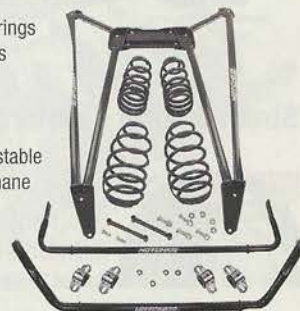

Sway Bar Sets

- Dramatically improved cornering potential
- Improved chassis balance and steering response
- Allows power to be applied earlier during corner exit



Part No.	Application	Front Bar Diameter	Rear Bar Diameter
2284	05-11 Corvette	1-1/4"	1-1/8"
2285	97-04 Corvette	1-1/4"	1"
2204	93-02 Camaro/Firebird	1-7/16"	1"
2278	04-06 Pontiac GTO	1-5/16"	3/4"
22109	10-11 Camaro (incl SS)	1-1/4"	1"

CHEVY WHEELS/TIRES

Time To Upgrade Your Style! | ASK TO SEE THE COMPLETE 2012 WHEEL CATALOG FOR MORE STYLES AND FINISHES

Classic styles that always look good!



TORQ THRUST D
VN1050 Series
(D = will clear disc brakes)
Gray Paint/Machined Lip
15"



S/S
610 Series
Chrome, Black
15/17/18/20"



R Window
541 Series
Polished
15"



Torq Thrust II
VN505/515 Series
Polished
14/15/16/17/18/20"
Custom offsets available upon request.

Chrome new styles, black for stealth appearance, machined to mix it up - you can't go wrong with these styles!



AR894
894 Series
Gloss Black Machined
18/20"



Nova
VN701 Series
Black, Gray/Machined
17/18/20"



Camaro SS
67 Series
Black, Silver
20"



Hustler
431 Series
Diamond Cut w/Black,
Chrome, Gray
17/18/20"



Hurst
MUTL Series
Shadow Chrome Polished
w/Matte Gunmetal Grey Inserts
20"



WL035
WL035 Series
Gloss Black/Machined, PVD
18/20/22"



WL021
WL021 Series
Matte Black/Machined
18"



VN805
VN805 Series
Chrome, Black/Machined
18/20/22/24/26"



Rockstar Car (KM775)
775 Series
Matte Black
18x8, 20x8, 20x10
(22x8.5 - S0)



Daytona
VN801 Series
Black, Chrome, Gray
17/18/20"



Americana II
AR Series
Black/Machined,
Graphite/Machined
18/20/22"



WL027
WL027 Series
Chrome with Black Windows
19/20/22"



Weiden
WD Series
Silver
19/20"



Protocol
V36 Series
Chrome, Black/Machined
15/16/17/18"



MB4
48 Series
Silver Painted
18"

Street or strip - performance tires to give you grip



Sportsman®
S/T Radial
Raised Whites!



TOYO TIRES
driven to perform®
PROXES™ TR



ET Drag®
Race Slicks



TOYO TIRES
driven to perform®
PROXES™ TR



Sportsman®
S/R Radial
H-Rated



TOYO TIRES
driven to perform®
PROXES™ ST II



ET Street



NEUTON
Tires

Don't settle for factory tires - even for daily drivers



MA-T1
Escapade
Premium Touring



MA-V1
High Performance Radial



MA-P1
Performance Touring



TOYO TIRES
driven to perform®
PROXES™ A



MA-Z1
Victra Z1



TOYO TIRES
driven to perform®
PROXES™ TT Sport
Ultra High-Performance
Summer Tire



MA-Z4S
Victra Z4S
All Season High
Performance Radial

DODGE CHALLENGER

Classic Drivetrain Components & Manuals for Every Mustang



What's Inside!

Intake:	Page 28
Intake Kit, Air Filters, Air Intake Systems, Nitrous Systems, Automotive Repair Manuals.	
Exhaust:	Pages 29-30
Stainless Steel Exhaust Systems, RSC Exhaust Systems, Muscle Car Exhaust, Muscle Car Exhaust Systems, Performance Exhaust Systems, Hush Thrush™, Super Turbo™ Mufflers, Headers, Stainless Steel Headers, Long Tube Headers.	
Ignition:	Page 31
intune, MaxEnergy, Battery, Sun Super Tachs®, 4-Channel Ignition Control.	
Engine:	Page 32
Hydraulic Roller Cams, Coolant Expansion Tanks, Air/Oil Separators, Superchargers, Intake Manifold, Head Studs.	
Mr. Gasket:	Page 33
Cap Covers, Fuse Box Cover, Door Sill Plates, Oil Dipstick Top, Subframe Connector, Engine Cover Insert, Ultra-Seal Exhaust Gaskets, Oil Pan Gasket, Strut Tower Brace.	
Brakes:	Page 34
Brake Pads, Caliper Covers, Brake Rotors.	
Drivetrain:	Page 35
Shifters, Six Shooter Couplers, Max-Gear Oil, Shocks.	
Suspension:	Page 36
Coilovers, Sport Coil Springs, Sport Sway Bar Set.	
Wheels:	Page 37
Classic Styles, New Looks, Performance Tires.	



AIR INTAKE



Typhoon Intake Kit

- Designed for increased performance, utilizing the finest quality components
- Guaranteed to provide more horsepower and increased acceleration
- Polished aluminum intake tube
- Includes K&N High-Flow, Washable/Reusable Air Filter
- Easy to Install
- K&N Million Mile Limited Warranty®

Part No. 692526TP — 05-12 Chrysler 300C, Dodge Charger, 09-11 Challenger, 05-08 Magnum 5.7, 6.1L



AirCharger® Intake Kit

- Guaranteed to increase horsepower and comes with a Million Mile Limited Warranty
- Designed to dramatically reduce intake restriction as it smooths and straightens air flow
- More usable power and acceleration throughout the engine's RPM range
- Filter is washable and reusable
- Easy to install

Part No. 631114 — 11-12 Dodge Charger, Challenger 5.7L

Part No. 631565 — 2012 Chrysler 300C, Dodge Challenger, Charger 6.4L

Part No. 571542 — 05-10 Chrysler 300C, Dodge Challenger, Charger, Magnum 5.7, 6.1L



High-Performance Air Filter

- High Air Flow with Excellent Filtration
- Designed to Increase Horsepower and Acceleration
- Washable and Reusable
- Will NOT Void Vehicle Warranty
- K&N Million Mile Limited Warranty®
- Environmentally Friendly

Part No. 332295 — 05-10 Chrysler 300C, Dodge Charger, Challenger, Magnum 5.7, 6.1L

Part No. 332460 — 11-12 Chrysler 300, Dodge Charger, Challenger, Magnum 5.7, 6.4L



The Performance Intake Company

Air Intake Systems

- Bolt on torque and horsepower
- Increased fuel efficiency
- Maximum airflow and filtration
- Exclusive SynthaFlow® technology

Part No. 350160 — Quick Fit style w/o Intake Tube

Fits 05-08 Chrysler 300, 05-08 Dodge Magnum, 06-08 Charger 5.7L

Part No. 350199 — Cool Air Dam System w/Intake Tube

Fits 05-10 Chrysler 300, 05-08 Dodge Magnum, 06-10 Charger, 08-10 Challenger 5.7L, 6.1L

Part No. 350193 — Cool Air Dam System w/Hood Scoop

Fits 06-10 Dodge Charger, 2008 Magnum 6.1L

Part No. 350210 — 11-12 Chrysler 300, Dodge Charger, Challenger 5.7L, 6.4L



Cold Air Intakes

- Cross-Link polyethylene box is engineered to each specific application for low restriction and an increase in air volume
- Cross-Link polyethylene air ducts are sculptured to give the engine less restrictive breathing
- Cleanable and reusable high-grade cotton filter media with five-layers of protection

Part No.	Application
16857152	04-10 Chrysler 300 5.7L
16257	11-12 Dodge Challenger 5.7L
16857154	08-10 Dodge Challenger 5.7L
16357	11-12 Dodge Charger 5.7L
16857153	05-10 Dodge Charger 5.7L
16861	05-10 Chrysler 300C/Dodge Charger, Magnum 6.1L



Stage 2 Intake Systems

- aFe Cold Air Intakes outperform all other intakes and produce increased horsepower, torque, and MPGs
- Replaces the stock intake tract and directs increased air flow with improved volumetric efficiency for maximum performance
- Pro 5R washable/reusable conical air filter improves airflow for increased horsepower and torque

Part No.	Application
5410712	05-10 Chrysler 300C/Dodge Charger, Challenger 5.7/6.1L
5412172	11-12 Chrysler 300C/Dodge Charger, Challenger 5.7/6.4L



ZEX Nitrous Systems

- ZEX™ Active Fuel Control™ adjusts fuel enrichment with variations in bottle pressure; you're never too rich or too lean
- ZEX™ electronics use the vehicle's throttle-by-wire TPS sensor to activate the nitrous system only at wide-open throttle
- Adjustable from 75 to 175 hp; perfect for mild to wild performance

Part No. 82322 — 08-12 Dodge Challenger 5.7/6.1L (75-175HP)

Part No. 82177 — 05-12 Dodge Charger, Magnum 5.7/6.1L (75-125HP)



Automotive Repair Manuals

Every manual is based on a complete teardown and rebuild.

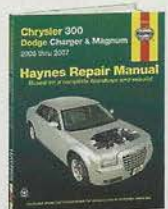

Part No. 25027 — 05-09 Chrysler 300, 06-09 Dodge Charger, 05-08 Dodge Magnum

MAGNAFLOW Exhaust PRODUCTS

Muscle Car Exhaust

- Stainless steel, mandrel-bent tubing
- Polished stainless steel tips
- All exhausts come with a Tru-X pipe



Dodge Challenger SRT-8 HEMI

SAMUEL HÜBINETTE

Drift Car Champion

Application	Part No.
Chrysler 300C HEMI	
05-12 5.7L V-8, Hemi, with Tru-X, (incl. AWD), dual rear exit	15629
300C SRT-8 HEMI	
05-12 6.1L V-8, Hemi, dual rear exit	16642
Dodge Challenger R/T HEMI Cat-Back	
09-12 5.7L V-8, Hemi, dual rear exit, Quad tips	16513
09-12 5.7L V-8, Hemi, dual rear exit, (reuses OEM tips)	16514
09-12 5.7L V-8, Hemi, Magnapack, dual rear exit, Quad tips	16515
09-12 5.7L V-8, Hemi, Magnapack, dual rear exit, OEM tips	16516
Axle-Back	
09-12 5.7L V-8, Hemi, dual rear exit, Quad tips	16893
09-12 5.7L V-8, Hemi, dual rear exit, (reuses OEM tips)	16894
08-12 6.1/6.4L V-8, Hemi, dual rear exit, uses OEM tips	16510
08-12 6.1/6.4L V-8, Hemi, Competition Series, Quad tips	16885
08-12 6.1/6.4L V-8, Hemi, Competition Series, uses OEM tips	16886

Application	Part No.
Challenger SRT-8 HEMI	
08-12 6.1/6.4L V-8, Hemi, dual rear exit	16509
Charger R/T HEMI	
06-11 5.7L V-8, Hemi, with Tru-X, (incl. AWD), dual rear exit	15628
Charger SRT-8 HEMI	
11-12 6.4L V-8, Hemi dual rear exit	15494
06-10 6.1L V-8, Hemi, dual rear exit	16642
Magnum R/T HEMI	
05-08 5.7L V-8, Hemi, with Tru-X, (incl. AWD), dual rear exit	15628
Magnum SRT-8 HEMI	
05-08 6.1L V-8, Hemi, with Tru-X, dual rear exit	16642

BORLA[®] EXHAUST

Stainless Steel Exhaust Systems

BORLA uses high-quality stainless steel, straight-through muffler design technology, and mandrel-bent pipes to deliver more power and torque, longer engine life, and fuel economy. All with a quick easy bolt-on-installation and backed by an unmatched Million Mile Warranty.



Application	Tip Style	Exit	Part No.
11-12 300C, Charger R/T 5.7L "Touring"	S Ov RI Ac	Split Rear	140442
11-12 300C, Charger R/T 5.7L "S-Type"	S Ov RI Ac	Split Rear	140443
05-10 300C, Charger RT/Magnum RT 5.7L V8 AT 4dr	S Ov RI Ac	Split Rear	140112
05-10 300C, Charger/Magnum SRT-8 6.1L V8 AT 4dr	S Rd RI Ac	Split Rear	140139
05-10 300C, Charger RT/Magnum RT 5.7L V8 AT 4dr	S Rd RI Ac	Split Rear	140125
11-12 Challenger SRT-8 6.4L "S-Type"	D Sq Ac	Split Rear	140435
11-12 Challenger SRT-8 6.4L "ATAK"	D Sq Ac	Split Rear	140435
09-11 Challenger 5.7L V8 AT/MT 2dr	D Sq Ac	Split Rear	140297
09-10 Challenger SRT-8 6.1L V8 AT/MT 2dr	D Sq Ac	Split Rear	140286

CORSA[®] PERFORMANCE EXHAUSTS

RSC Exhaust Systems

- All premium stainless steel construction, crafted with pride and precision in the USA
- Patented CORSA Reflective Sound Cancellation Technology
- Dual rear exit with single handcrafted Pro-Series tips for enhanced vehicle appearance
- No welding required; bolt-on installation



Application	Part No.
11-12 Dodge Challenger SRT-8 6.4L, Sport, Dual Rear w/GTX Style Tips	14426
11-12 Dodge Challenger SRT-8 6.4L, Xtreme, Dual Rear w/GTX Style Tips, Auto. Trans.	14427
11-12 Dodge Challenger SRT-8 6.4L, Xtreme, Dual Rear w/GTX Style Tips, Manual Trans.	14424
08-10 Dodge Challenger SRT-8 6.1L, Dual Rear w/GTX-Style Tips	14138
09-10 Dodge Challenger R/T 5.7L A/T Only, Dual Rear w/ GTX Style Tips	14428
09-10 Dodge Challenger SRT-8 6.1L, Dual Rear w/GTX-Style Tips	14438
09-10 Dodge Challenger R/T 5.7L M/T Only, Dual Rear w/ GTX Style Tips	14429
11-12 Charger 5.7L, Xtreme, Dual Rear w/3" Pro Series Tips	14537
11-12 300C 5.7L, Xtreme, Dual Rear w/3" Pro Series Tips	14522
05-10 300C, Charger/Magnum SRT-8 6.1L	14178
05-10 300C, Charger/Magnum R/T 5.7L	14177

EXHAUST



Muscle Car Exhaust Systems

- More muscle, more power, and more sound
- Amazing 29 HP / 25 ft/lbs gain with instant throttle response and a sound that is classic muscle
- Thanks to the twin MBRP mufflers and resonators combined with 3" mandrel-bent tubing, the Challenger now sounds as cool as it looks
- Real quad retro '70s style tips in mirror-finished T304 stainless steel

XP Series	Pro Series	
Part No.	Part No.	Application
S7102409	S7102304	08-11 Dodge Challenger 6.1L, "Cool Duals"
S7104409	57104304	09-11 Dodge Challenger 5.7L, "Cool Duals"
57106409	57106304	08-11 Dodge Challenger 3.5L, Single Side Exit



Hush Thrush™ Super Turbo™ Mufflers

- That vintage sound you love with the performance you expect
- The improved tri-flow design enhances flow and performance
- All mufflers are reversible for maximum installation and flexibility
- The perfect choice for that classic hot rod and today's muscle car

Part No.	Description
17631	2.25" In/Out, Offset/Center
17632	2.25" In/Out, Offset/Offset
17633	2.5" In/Out, Offset/Center
17634	2.5" In/Out, Offset/Offset
17635	3" In/Out, Offset/Center
17636	3" In/Out, Offset/Offset



Tuned Length Headers

All BBK 1-3/4" Short Tuned Length Magnum, Challenger, Charger, and 300 exhaust headers are manufactured with 1 5/8" CNC mandrel-bent tubing for unrestricted airflow and a one-piece laser-cut flange for added strength and durability. ALL BBK headers are pressure tested to ensure leak-free performance. Each header has been designed and dyno tested at the BBK headquarters in Southern California to maximize performance. Designed for direct bolt-on replacement to the factory exhaust system.



Part No. 4012 — 05-12 Chrysler HEMI Cars



Performance Exhaust Systems

- All CNC mandrel-bent 16-gauge aluminized steel tubing
 - Fully MIG welded 16-gauge aluminized steel performance muffler(s)
 - All necessary clamps, hangers, and mounting hardware
- Part No. 17405** — 05-10 Chrysler 300C, Dodge Charger, Magnum 5.7L, Dual
Part No. 817502 — 11-12 Chrysler 300C/Dodge Charger, 5.7L, Force II, Stainless
Part No. 817508 — 11-12 Chrysler 300C/Dodge Charger, 5.7L, American Thunder, Stainless
Part No. 817461 — 09-10 Dodge Challenger 5.7L, Dual Stainless
Part No. 817499 — 09-12 Dodge Challenger 6.1/6.4L, Dual Stainless



Long Tube Headers

- Increase hp and torque throughout RPM range
- Improved throttle response
- Reduced under hood temperature
- Increased passing power
- Increased low-end torque
- Makes engine more sensitive to other modifications (intake, chip, supercharger, etc.)
- Improved engine compartment appearance
- Improved fuel economy



Part No. 6965S — 05-12 Dodge Charger/Magnum/Challenger, Chrysler 300C SRT-8, 6.1/6.4L



Stainless Steel Headers

This exciting BORLA competition stainless steel long tube header features 1-3/4" primaries leading to a four-into-one collector. Exiting the collector is a 2-1/2" outlet pipe. Connecting to each collector outlet pipe using a slip fit is a left and right header outlet pipe each consisting of 2-3/4" tubing. Header outlet pipes allow a factory type slip fit connection to the stock or Borla Cat-Back™ Exhaust System. For off-road or competition use only.



Part No. 17250 — 05-11 Dodge Challenger/Charger/Magnum, Chrysler 300C 6.1L SRT-8
Part No. 17256 — 09-10 Dodge Challenger/Charger, Chrysler 300C 5.7L R/T

DIABLOSPORT
GASOLINE AND DIESEL TUNING SYSTEMS



The DiabloSport inTune is the next generation of tuning tools, a total revolution in the tuning industry. The inTune contains innovative features not available anywhere else.

- Least expensive full color touchscreen available
- USB connectivity
- Easy to use
- Free automatic updater
- Removable cables
- External sensor inputs
- One part number for all applications, including gas and diesel
- Virtually no limit to the amount of custom tunes the inTune can hold
- Most adjustable parameters in the market
- Preloaded with multiple "canned" tunes for increased HP, TQ and MPG
- Designed, engineered and manufactured in the USA



Part No. I1000

HYPERTECH
The World Leader In High-Performance Engine Tuning Products



Adjustable features so you can customize your vehicle exactly the way you want in just minutes.

- Automatic transmission shift points & firmness
- Top-speed limiter
- RPM "rev" limiter
- Diagnostics
- Cooling fan temps
- Internet updates
- Speedometer correction for non-stock rear gears

Part No. 52501 — 05-10 Challenger/Charger/Magnum/300 SRT-8 6.1L
05-10 Challenger/Charger/Magnum/300 5.7L



Silver Tip Spark Plugs

- Only ACCEL offers a gap-able center electrode without the use of specialty tools
- Only plug offered in a colder heat range that allows the use of nitrous, superchargers, turbochargers, or high compression
- Silver is the best electrical conductor which allows for a wider heat range and is extremely resistant to fouling



Part No. 457S — 08-Up Chrysler 5.7/6.1L

Part No. 461S — 08-Up Chrysler 5.7/6.1L, 1 Step Colder



MSD DIS-4 Plus Distributorless 4-Channel Ignition Control

- MSD's DIS Ignition Controls are designed for engines with coil pack, waste spark ignition systems
- Each Control delivers full power Capacitive Discharge sparks from idle through racing rpm
- Below 3,000 rpm there is a series of multiple sparks that last for up to 20° of crankshaft rotation to improve idle, starting and throttle response
- Rotary dials provide easier, and more precise adjustments of the overrev limiter and the holeshot rev limit

Part No. 62152

Blaster Replacement Coils

- Fire up your late model Hemi with a set of MSD's Blaster Coils
- The Coils are a direct bolt-in and are spec'd with superior materials and winding ratios to improve the output of the coil while retaining the factory fit



Part No. 82558—Late Model (06-Up) Mopar HEMI engines (set of 8)

Part No. 82568—Early (03-05) Mopar HEMI engines (set of 8)



The Performance Legend

Sun Super Tachs®

Sun Super Tachs® are the world's best recognized tachometers. Highly accurate. Fast needle response-90% of full scale in 4/10 of a second.

Part No.	Description	Color
Chrome Bezel		
CP7901	3-3/8" dial face	Black
CP7903	3-3/8" dial face	White
Black Bezel		
CP7906	2-5/8" dial face	Black
CP7904	2-5/8" dial face	White



THE ULTIMATE POWER SOURCE

The Optima Battery

- Spiral cell design protects it from heat and vibration
- If battery is damaged, it will not leak and will continue to work
- Delivers more dependable starts in extreme weather
- High starting capacity

Part No. 3478 — 800 CCA - 104 Minutes

- Faster and a more efficient recharge
- Delivers more power quickly during peak demand
- Consistent voltage throughout delivery

Part No. D3478 — 650 CCA - 120 Minutes



ENGINE



Xtreme Fuel Injection (XFI™) Hydraulic Roller Cams Bolt-in up to 61+ horsepower for your new Hemi!

- Dramatically increase engine horsepower and torque, yet retain compatibility with reprogrammed OEM vehicle computer systems
- Uniquely engineered for street performance applications
- For 03-up Chrysler 5.7L and 6.1L HEMI engines

Part No.	RPM Range	Adv. Duration	Duration @.050"	Valve Lift	Sep. Angle
11250111	1500-5800	260/264	216/220	.528/.531	113°
11250211	2000-6200	273/277	224/228	.547/.550	114°



American ingenuity and integrity, since 1968.

- Manufactured from aluminum for strength
- Direct bolt-in to factory tank
- A much stronger and better looking tank than the plastic factory tank
- Baffled and complete with cap, integral mounting bracket, and fittings to ensure a factory replacement part
- Finish can be left as is, polished, chromed, or powder-coated for a custom look
- Fits: 2005 & Up Dodge Cars with 2.7, 3.5, 5.7 and 6.1L Engines

Part No. 63498 — Power Steering Tank

Power Steering Tank



Coolant Expansion Tanks

- Direct bolt-in replacement to stock plastic tanks
- Fabricated of aluminum for strength – can be polished, chromed, powder-coated, or left as-is for a race look
- Plastic coolant tanks fail after repeated high heat situations
- Has a built-in overflow expansion reservoir like the factory tank
- Features a robust billet aluminum filler neck, fittings, and power steering tabs
- Increased coolant capacity over stock tanks
- Fits: 2005 & Up Dodge/Chrysler Challenger, Charger, Magnum with 2.7, 3.5, 5.7 and 6.1L Engines

Part No. 63497 — Coolant Expansion Tank with two power steering tab locations

Part No. 63499 — Coolant Expansion Tank with one power steering tab location



Air/Oil Separators

- Plumbed into a vehicle's PCV system to capture the excess crankcase vapors and the residual oil mist from re-entering the intake track
- Polished Billet Aluminum body compliments any engine compartment
- Features a bottom drain with elbow that makes draining the collected oil virtually mess-free



Part No. 85472 - 08-10 Chrysler 5.7/6.1L



Cylinder Head Studs

- ARP uses a premium grade 8740 alloy that is rated far superior to "aircraft" quality
- Each stud is placed vertically in special racks and precisely heat-treated to 200,000 psi
- Each stud is centerless ground to make it as close to perfectly concentric as possible
- ARP studs are thread rolled after heat-treat, which gives them about 1000% (that's ten times) better fatigue strength than those studs that are threaded prior to heat-treat



Part No. 2444300 — Chrysler 5.7L and 6.1L Hemi



E-Force Superchargers for Chrysler HEMI

These complete supercharger systems provide maximum flow, minimum temperature rise, quiet operation, and reliability only the Edelbrock name can guarantee. They feature minimum air restriction in and out of the supercharger for optimal flow. They also include individual 7" long intake runners that allow for maximum low end torque and great drivability.



Part No. 1536 - Street Supercharger: 05-10 Chrysler 6.1L HEMI LX and LC

Part No. 1530 - Street Supercharger: 06-08 Chrysler 5.7L HEMI LX

Part No. 1532 - Street Supercharger: 09-10 Chrysler 5.7L HEMI LX and LC

Part No. 1537 - Competition Supercharger: 05-10 Chrysler 6.1L HEMI LX and LC

Part No. 1531 - Competition Supercharger: 06-08 Chrysler 5.7L HEMI LX

Part No. 1533 - Competition Supercharger: 09-10 Chrysler 5.7L HEMI LX and LC



RPM Air-Gap Dual Quad Intake Manifold

This manifold is perfect for those looking to swap this modern powerplant into their classic Chrysler or street rod. Our RPM Air-Gap Dual-Quad manifold added over 30 ft/lbs. of torque. The dual-quads make great power while providing a nostalgic look.



Part No. 7528 — 03-10 Dodge 5.7L Hemi

Superchargers

06-08 Dodge Charger, Magnum, Chrysler 300C and 08-10 Dodge Challenger 6.1L SRT-8

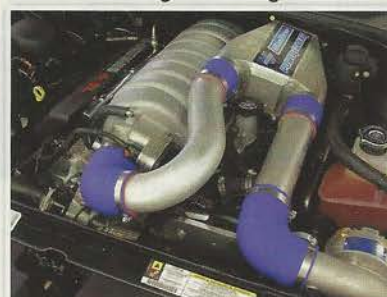

Type:	V-3 Si-Trim High Output
Stock HP/TQ:	425/420
Vortech HP/TQ:	560/510
Boost (PSIG):	6.5
CARB E.O.:	In Process
5.7L Hemi Systems Also Available	

Part No. CL218030L

CHALLENGER



Cap Covers

- Easy install
- Slides over stock cap
- Polished aluminum finish
- Customize your engine compartment in minutes

Part No. 6721G — Radiator Cap Cover: 08-11 Dodge Challenger R/T
Part No. 6723G — Oil Cap Cover: 08-11 Dodge Challenger R/T
Part No. 6724G — Power Steering Cap Cover: 08-11 Dodge Challenger R/T



Fuse Box Cover

- Easy install
- Slides over stock fuse box cover
- Polished aluminum finish

Part No. 6722G — Fuse Box Cover: 08-11 Dodge Challenger R/T



Door Sill Plates

- Sold as a set of 2
- Easy install
- Black anodized finish
- Protect your door sills from scratches and scuffs

Part No. 6727G — Door Sill Plates: 08-11 Dodge Challenger R/T



Oil Dipstick Top

- Easy install
- Polished aluminum finish
- Customize your engine compartment in minutes

Part No. 6725G — Oil Dipstick Top: 08-11 Dodge Challenger



Subframe Connector

- Ties front and rear subframe together
- Increases chassis strength
- Weld-in installation
- Made in the USA

Part No. 30401

Subframe Connectors:
08-11 Dodge Challenger R/T

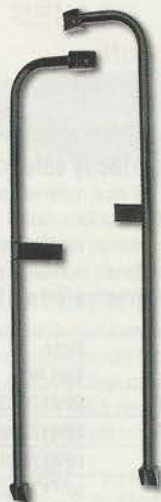

Engine Cover Insert

- Easy install
- Replaces stock engine cover insert
- Polished aluminum finish
- Includes hardware

Part No. 6720G — Engine Cover Insert: 08-11 Dodge Challenger R/T



Ultra-Seal Exhaust Gaskets

- Manufactured from high temperature graphite facing/ steel core exhaust material
- Expanded steel core provides stability and maximum torque retention
- Graphite facing provides excellent heat resistance and thermal conductivity to transfer heat away from cylinder head
- Conforms to and seals minor surface irregularities



Part No. 7594
Exhaust Gasket: Chrysler/
Dodge 5.7L/6.1L Hemi, 02-10

Oil Pan Gasket

- Manufactured from high-temperature silicone blend rubber
- Conforms easily to uneven surfaces and allows superior sealing without deteriorating or cracking under excessive heat and pressure
- For OE replacement, high-performance street and drag racing

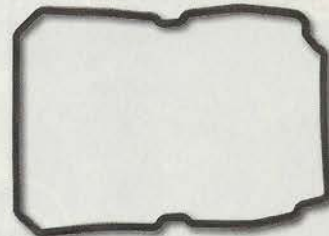

Part No. 8687G
08-Up Dodge Challenger 5.7L V8,
Auto. Trans., 5-Speed 5WA580



Strut Tower Brace

- Reduces flex between strut towers by strengthening unibody
- Simple installation with basic hand tools in less than one hour
- Clears factory and most aftermarket engine dress-up covers
- Fabricated from square mild steel tubing
- Powder-coated for durability
- Made in the USA

Part No. 39000 — Strut Tower Brace: 08-11 Dodge Challenger SE, R/T

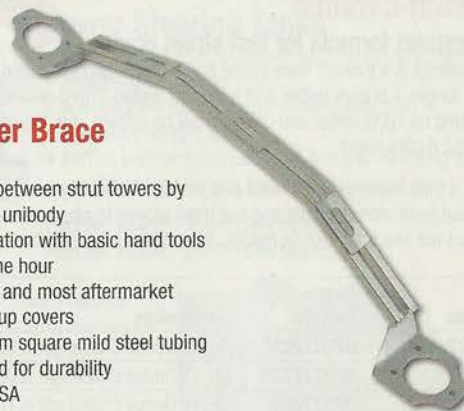

BRAKES



Slotted Brake Rotors

Developed to beat the challenges of high-performance driving and severe duty brake demands, Power Slot rotors run cooler, extend brake life, and significantly improve wet and dry brake performance. Bright Silver Cadmium Plated.



Front Part No.	Rear Part No.	Application
Chrysler		
12663061SL/R	12663062SL/R	05-12 300C R/T 5.7L
12663063SL/R	12663064SL/R	05-12 300C SRT-8 6.1L
Dodge		
12663061SL/R	12663062SL/R	06-12 Challenger/Charger/Magnum R/T 5.7L
12663063SL/R	12663064SL/R	06-12 Challenger/Charger/Magnum SRT-8 6.1L

MGP CALIPER COVERS



NEW

- Enhance your wheel appearance
- Protects the wheels from brake dust
- Easy installation, less than 10 minutes
- 6061-T6 aerospace aluminum
- CNC precision engraving for customization
- Hydraulically formed to fit each caliper
- Powder coating and custom paint match

Part No.	Application
12001SMGPR	05-10 Chrysler 300C, Dodge Challenger, Charger, Magnum 5.7, MGP logo, Red
12001SMGPS	05-10 Chrysler 300C, Dodge Challenger, Charger, Magnum 5.7, MGP logo, Silver
12005SMGPR	05-10 Chrysler 300C, Dodge Challenger, Charger, Magnum V6, MGP logo, Red
12005SMGPS	05-10 Chrysler 300C, Dodge Challenger, Charger, Magnum V6, MGP logo, Silver

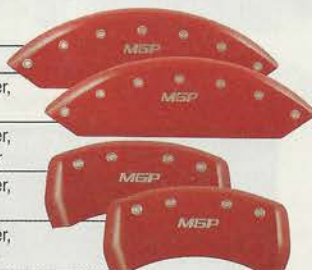

EBC BRAKES

Redstuff Ceramic

Superstreet formula for fast street driving.

This material is a Kevlar® fibre-based brake compound enhanced with ceramic particles. It lasts longer, it brakes better, and is quieter. Being a hard-wearing pad, bed-in times can be as long as 1000 miles, and drivers must be patient until the pad takes up the shape of their disc (brake rotor).

This is a truly impressive fast road pad for repeated heavy braking. It emits far less dust than semi-metallic pads and has been proven to stop a passenger car/sedan/sport compact/hot hatch 13 metres quicker than OEM pads from 100mph/160kph.

Front Part No.	Rear Part No.	Application
DP31724C	DP317222C	09-11 Dodge Challenger 3.5L
DP31724C	DP317222C	09-11 Dodge Challenger 5.7L
DP31764C	DP31788C	08-11 Dodge Challenger 6.1L
DP31724C	DP317222C	06-10 Chrysler 300C/06-12Dodge Charger 5.7L
DP31764C	DP31788C	06-10 Chrysler 300C/Dodge Charger 6.1L

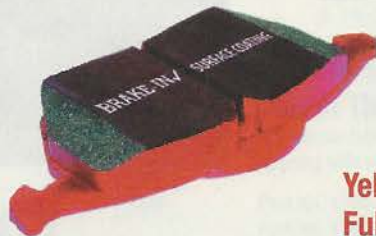

EBC BRAKES

Yellowstuff Full Race Pad

Ultra-high friction pads for race use but perfectly safe for street use.

Although a full race material and capable of high-temperature use with very good wear life, this new formulation sets a new trend in race type brake pad compounds that can be used on the highway. The "bite" from cold is superb which is uncommon with race materials (normally requiring warm-up) and makes this a pad which can be safely used on both street and track.

Front Part No.	Rear Part No.	Application
DP41724R	DP417222R	09-11 Dodge Challenger 3.5L
DP41724R	DP417222R	09-11 Dodge Challenger 5.7L
DP41764R	DP41788R	08-11 Dodge Challenger 6.1L
DP41724R	DP417222R	06-10 Chrysler 300C/06-12Dodge Charger 5.7L
DP41764R	DP41788R	06-10 Chrysler 300C/Dodge Charger 6.1L



HPS

Performance Street Compound

Recommended for import and domestic automobiles. This unique Ferro-Carbon compound offers a higher coefficient of friction over stock brake pads and can provide you 20-40% more stopping power and higher resistance to brake fade than standard replacement pads.

- Increased stopping power
- High friction/torque hot or cold
- Extended pad life
- Low dust
- Virtually noise-free

Product Code: F



Performance-Ceramic Luxury & Touring Compound

Recommended for import and domestic automobiles, luxury SUVs, sport trucks and vans. Performance-Ceramic is a specially formulated ceramic composite developed to meet the ultra-low dust, low noise performance of OE ceramic brake pads. Performance-Ceramic pads feature a fade resistant, linear friction profile that produces improved braking over OE with smooth engagement characteristics.

- Increased stopping power
- Increased rotor life
- Extended pad life
- Ultra-low noise
- Extremely quiet

Product Code: Z

Front Part No.	Rear Part No.	Application
HB509_678	HB508_675	09-11 Dodge Challenger R/T
HB507_711	HB508_675	09-11 Dodge Challenger SE
HB563_656	HB194_570	09-11 Dodge Challenger SRT-8
HB509_678	HB508_675	06-11 Dodge Charger, 05-08 Magnum R/T
HB507_711	HB508_675	06-11 Dodge Charger, 05-08 Magnum SE
HB563_656	HB194_570	06-10 Dodge Charger, 06-07 Magnum SRT-8
HB509_678	HB508_675	05-10 Chrysler 300C 5.7L
HB563_656	HB194_570	05-09 Chrysler 300C SRT-8
HB507_711	HB508_675	05-10 Chrysler 300 RWD, 3.5L
HB509_678	HB508_675	05-10 Chrysler 300 AWD, 3.5L



Comp/Stick Kits For Chrysler and Dodge

Dress up your 2008 or later Chrysler 300, Dodge Magnum, Charger or Challenger* shifter! The latest offering from Hurst comes with a CNC-machined black knob, classic-looking Hurst stainless steel stick sleeve, and a black CNC-machined console plate. Revive the Hurst and Mopar heritage on your new Chrysler or Dodge! *With Auto Stick

Part No.	Application/Description
5380402	08-Up Challenger, Black Plate/Black Knob
5380403	08-Up Challenger, Chrome Plate/White Knob
5380404	08-Up 300, Magnum & Charger, Black Plate/Black Knob
5380405	08-Up 300, Magnum & Charger, Chrome Plate/White Knob
5380410	05-07 300, Magnum & Charger, Black Plate/Black Knob
5380411	05-07 300, Magnum & Charger, Chrome Plate/White Knob

Billet/Plus 2 Shifter For 09-Up Dodge Challenger 6-Speed

- CNC-machined stainless steel stick assembly
- CNC-machined aluminum carrier arm
- Nylon-lined spherical pivot bearing
- Shift throw reduced for quicker shifts
- Smooth positive mechanism
- Bolt-on classic chrome-plated stick and white knob
- Front and rear isolated mount assembly
- CNC-machined stick adapter accepts Classic Hurst stick or OEM stick

Part No. 3916020



Modern Muscle Roll/Control Kit

- Used primarily in drag racing to provide positive locking action to the front wheels of race cars
- Field serviceable for cleaning or rebuilding
- Kit includes solenoid valve, snap-action switch, indicator light, 4-amp fuse, mounting screws and installation instructions

Part No. 5671517 - 08-10 Dodge Challenger SRT8, R/T



Drag Shocks

- 90/10 front shocks for maximum weight transfer
- 70/30 front shocks for street/strip
- Twin tube body
- Chrome-plated piston rod
- Multi-stage valving

Part No. 40530 — Front 90/10 Drag Shocks 08-10 Challenger

Part No. 40531 — Front 70/30 Drag Shocks 08-10 Challenger

Part No. 40532 — Rear 50/50 Drag Shocks 08-10 Challenger



Fidanza

Aluminum Flywheel

- 6061-T6 Aluminum
- 1050 High carbon steel friction surface
- 1050 Steel ring gear
- CNC machined
- Aerospace fasteners
- Many applications SFI approved

Part No. 194611 — 09-11 Dodge Challenger 5.7/6.1L 6-Speed



Max-Gear Oil

Max-Gear is an ultra-tough, high performance GL-5 gear oil designed to provide maximum protection for heavily loaded gears while reducing friction. Max-Gear virtually eliminates gear and bearing wear - even under severe conditions caused by high loads or sudden shock loads. Max-Gear allows gears to run cooler, quieter, smoother and longer.

Part No. 01300 — 75W90, Quart

Part No. 01301 — 75W140, Quart

Part No. 01303 — 85W140, Quart



Six Shooter Couplers for Mopar Cars

Made for the HEMI powered Chrysler 300, Dodge HEMI Magnum and Charger. These ultra trick couplers are the answer to those weak factory rubber couplers. The problem of OEM couplers breaking when you really get "hooked up" is finally solved! Made of fully machined 6061-T6 aluminum featuring specially formulated urethane inserts provides NVH dampening that your ride deserves!

Part No. 41650 — Sold as each

SUSPENSION



Pro-Street-S Coilovers - Adjustable Ride Height The Next Level of Suspension Performance

- Easy ride-height/corner weight adjustability-lowering
- Designed for maximum street and track performance
- Rust-free stainless steel technology for ease of adjustment - year after year
- One-year warranty

Part No. 28110711 - 11-12 Challenger SRT8
 Part No. 2895711 - 08-10 Challenger (F: 0.0-2.5" / R: 0.0-2.0")
 Part No. 2895711 - 06-10 Charger (F: 0.0-2.5" / R: 0.0-2.0")

Pro-Plus Performance Handling Package

- Matched performance pro-kit springs and sway bars = superior handling for the serious enthusiast
- Precise turn-in response, improved handling and enhanced cornering grip - in any performance - driving situation



Year	Model	Lowering Front-Rear (in)	Anti-Roll Front/Rear (mm)	Pro-Plus Pro-Kit+Anti-Roll Kit Part No.
11-12	Challenger R/T	I/D	I/D	28111880
08-10	Challenger SRT-8	0.8 / 0.8	35 / 19	2895880
11-12	Charger R/T	I/D	I/D	28105880
06-10	Charger R/T	1.5 / 1.9	30 / 16	2876880

HOTCHKIS SPORT SUSPENSION

Sport Coil Springs

When we decided to manufacture coil springs for the Challenger, we took our time and researched other springs on the market. With those springs in mind, we found a great combination of performance and comfortable ride characteristics. Our springs feature a linear rate design and come complete with urethane bump stops.



Part No. 19107 - 08-09 Challenger SRT-8 (F: 5/8" / R: 1")

Sport Sway Bar Set

- Lightweight strong hollow sway bars are 1-1/2" (38mm) (100% stiffer than stock) Front and 3/4" (19mm) (150% stiffer than stock) Rear
- Sport sway bars are complete with polyurethane bushings, special brackets and installation hardware
- Finished in durable gloss black powder-coat



Part No. 22107 - 08-11 Dodge Challenger RT, 09-12 Dodge Challenger SRT-8
 Part No. 22111 - 11-12 Dodge Charger RT
 Part No. 22101 - 05-09 Chrysler 300C, Dodge Charger SRT-8



Pro-Kit

- High-performance handling and aggressive good looks
- Stop quicker, corner faster, and get better MPG
- Progressive spring design for excellent ride quality



Part No.	Application	Lowering
28111140	11-12 Challenger R/T	F: I/D / R: I/D
2895140	09-10 Challenger R/T	F: 0.8"/R: 0.8"
2895140	08-10 Challenger SRT-8	F: 1.7"/R: 1.7"
2876140	06-10 Charger R/T	F: 1.5"/R: 1.9"
2873140	05-10 Chrysler 300C	F: 1.6"/R: 1.6"
28105140	11-12 Charger V8	F: I/D / R: I/D



Variant 1 Coilovers - Perfect Street Performance

Sporty Handling with factory pre-set damping

The ideal system for customers wishing to rely on the experience of our engineers to set the damper setting, yet determine their own degree of lowering.

Part No. 10228006 - 08-10 Challenger SRT-8; 09-10 Challenger R/T (F: 0.8-2.0" / R: 0.9"-2.1")
 Part No. 10228006 - 06-10 Charger RT (F: 0.8-2.0" / R: 0.9"-2.1")
 Part No. 10227016 - 05-08 Magnum R/T (F: 0.8-2.0" / R: 0.9"-2.1")



Variant 2 Coilovers - Perfect Street Performance

Sport Handling with adjustable rebound damping

This system is intended for the experienced driver who wishes not only to determine the individual lowering of his vehicle, but also to carry out setup adjustments. The adjustable rebound damper allows adjusting the pitch and roll behavior of the vehicle, and therefore the driving pleasure can be adapted to the driver's own requirements.

Part No. 15228006 - 08-10 Challenger SRT-8; 09-10 Challenger R/T (F: 0.8-2.0" / R: 0.9"-2.1")
 Part No. 15228006 - 06-10 Charger R/T (F: 0.8-2.0" / R: 0.9"-2.1")
 Part No. 15227016 - 05-08 Magnum R/T (F: 0.8-2.0" / R: 0.9"-2.1")



MOPAR WHEELS/TIRES

ASK TO SEE THE COMPLETE 2012 WHEEL CATALOG FOR MORE STYLES AND FINISHES | **Challengers Need Wheels - Go Classic Or Modern Look**

Classic styles that always look good!

						
AR105 105M Series Chrome, Black/Machined, Anthracite 17/18/20/22"	Nova VN701 Series Black, Gray/Machined 17/18/20"	Challenger 1159 Series Black 20"	VN805 VN805 Series Chrome, Black/Machined 18/20/22/24/26"	Challenger 1159 Series Chrome 20"	Daytona VN801 Series Black, Chrome, Gray 17/18/20"	SRT 8 1150 Series Chrome 20/22"

Chrome new styles, black for stealth appearance, machined to mix it up - you can't go wrong with these styles

					
MR118 MR118 Series Matte Black 17/18"	WL035 WL035 Series Gloss Black/Machined, PVD 18/20/22"	LSS-10 - RWD LSS Series Machined Black/Black Lip Machined Black/ Chrome Lip 20/22"	Hurst MUTL Series Shadow Chrome Polished w/ Matte Gunmetal Gray Inserts 20"	WL027 WL027 Series Chrome with Black Windows 19/20/22"	Challenger SRT8 67 Series Black/Silver, Silver Painted 18"
					
Rockstar 775 Series Matte Black 17/18/20/22"	Speedway - FWD/RWD AR861 Series 1 Pc. Aluminum Painted Gloss Black 16x7, 17x7.5, 18x8	Phantom 882 Series Matte Black 17/18/20"	Hustler 431 Series Diamond Cut w/Black, Chrome, Gray 17/18/20"	Wolverine 122 Series Chrome, Black w/Diamond Cut 17/18/20"	Saber 291/292 Series Chrome/Black 16/17/18/20"
					
Americana II AR Series Black/Machined, Graphite/Machined 18/20/22"	Rockstar 775 Series Matte Black 17/18/20/22"	Speedway - FWD/RWD AR861 Series 1 Pc. Aluminum Painted Gloss Black 16x7, 17x7.5, 18x8	Phantom 882 Series Matte Black 17/18/20"	Wolverine 122 Series Chrome, Black w/Diamond Cut 17/18/20"	Saber 291/292 Series Chrome/Black 16/17/18/20"

Street or strip - performance tires to give you grip

	Sportsman® S/T Radial Raised Whites!	
	Sportsman® S/R Radial H-Rated	
	ET Street	
	ET Drag® Race Slicks	

Don't settle for factory tires - even for daily drivers

	MA-T1 Escapade Premium Touring		MA-V1 High Performance Radial
	MA-P1 Performance Touring		TOYO TIRES driven to perform® PROXES 4
	MA-Z1 Victra Z1		TOYO TIRES driven to perform® PROXES TI Sport Ultra High-Performance Summer Tire
	MA-Z4S Victra Z4S All Season High Performance Radial		NEW

American Racing

Custom Wheels



VN701 NOVA



VN801 DAYTONA



VN805 BLVO



VN425
TORO THRUST SL



ACCESSORIES



05-10 Ford Mustang Body Styling

Designed for a perfect fit

- Easy to install - hardware and instructions included
- Most items made from tough urethane
- Limited lifetime warranty on urethane items

Part No.	Application
95070740	GT Front Fascia Gen 1
95070743	GT Rear Fascia Lip Gen 1
95070742	Side Skirt Set w/ Door Fillers V6 & GT Gen 1
95070747	GT Kit Gen 1 - includes Front Fascia, Skirts, Door Fillers & Rear Lip
95070741	V6 Front Fascia Gen 1
95070744	V6 Rear Fascia Lip Gen 1
95070746	Window Louvers Gen.1 (fits V6 and GT)



Part No.	Application
95070749	Window Louvers Gen.2 (fits V6 and GT)
95070738	Window Ducts Gen 3 (fits V6 and GT)
95070737	Side Ducts (fits V6 and GT)
95070745	Rear Wing Gen.1 - 3 Piece kit (fits V6 and GT)
95073100	Chrome Headlight Bezels (fits V6 and GT)
95073101	Chrome Taillight Bezels (fits V6 and GT)
95073750	Rear Tail Light Panel Black Plastic (fits V6 and GT)



Twin Scoop Hoods

Functional Ram-Air upgrade available

Part No.	Application
GHF504	05-09 Mustang
GHD301	05-07 Dodge Magnum



Classic Billet Grilles



Part No.	Application
20027	2010-2012 Camaro (All) Phnom Billet, Also Available in Black
20433	2011-2011 300/300C 1 Pc Billet Grille, Also Available in Black
21519	2010-2012 Ford Mustang GT - Billet Grille Overlay - 3 Pc - GT



Light Covers

- Add Dramatic Styling & Protection
- Easy "No Holes to Drill" Installation
- Custom designed for each vehicle
- Includes all hardware and instructions



Headlight Covers

Part No.	Application
GT0280S	10-12 Camaro
GT0280FS	10-12 Camaro Fog Light
GT0161S	08-12 Challenger 2 Piece Kit
GT0161FS	08-12 Challenger Fog Lt
GT0177S	11-12 Charger
GT0177FS	11-12 Charger Fog Lights
GT0251S	2010-11 Mustang Headlight Covers
GT0251FS	10-12 Mustang Fog Lt Cvr

Older model applications are available

Taillight Covers

Part No.	Application
GT4170	10-12 Camaro Rear Blackout Panel
GT4168	10-12 Camaro
GT4165	08-12 Challenger
GT4163	08-12 Challenger Rear Panel Solid
GT4164	08-12 Challenger Rear Panel w/Opening
GT4151	10-12 Mustang
GT4154	10-12 Mustang Rear Blackout Panel

Older model applications are available



Mustang Accessories

Part No.	Application
3190	10-12 Mustang Side Window Louvers
3180	05-09 Mustang Side Window Louvers
1322180	05-09 Mustang Chrome Taillight Trim
1377080	05-09 Mustang Chrome Gas Door Cover



Brilliant Solution New Car Care Kit

Kit includes:

- Ultimate Wash & Wax, ultra-plush microfiber wash mitt, and Water Magnet™ microfiber drying towel
- Ultimate Liquid Wax with a soft foam applicator and Supreme Shine™
- Microfiber Towel Tires, Endurance® Tire Gel, and applicator

Part No. G3200

Chevy Camaro 2010-Current



LED Hood Dayliner #280602

Aluminum Grille Insert (2-piece kit) #91160



Mirror Overlays #400604



Rocker Panel Trim #9751501



Door Handle Covers #400603

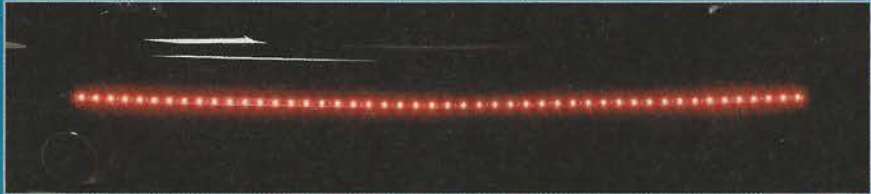

LED Rear Accent Light Bar - (Brake, Reverse and Turn Signal Functions) #900648



Stainless Steel Side Vent Accents #402662



Fuel Door Cover #400602

Interior Lighting

	Bulb	Quantity on vehicle
Trunk	T1.75	
License	194	2
Vanity	VANITY	2
Map	194	2
Glove Box	N/A	N/A

Exterior Lighting

	Bulb	Quantity on vehicle
Headlight	H13 / D1S	2
Fog Light	894	2
Front Side Marker	194	2
Rear Side Marker	194	2
Reverse	N/A	N/A
Front Turn Signal	3157	2
Rear Turn Signal	3157	2
Tail Light	3157	2



Chrome trim & lighting also available for many other popular vehicles

Replacement Auto Lighting Dodge Challenger 2008-Current



Interior Lighting	Bulb	Quantity on vehicle
Trunk	RIGID LOOP	1
License	194	2
Vanity	VANITY	4
Map	1.75 FESTOON	2
Glove Box	194	1



Exterior Lighting	Bulb	Quantity on vehicle
Headlight	H13 / D1S	2
Fog Light	H10	2
Front Side Marker	194	2
Rear Side Marker	194	2
Reverse	921	2
Front Turn Signal	3157	2
Rear Turn Signal	3157	2
Tail light	3157	2



Also available for many other popular vehicles

Replacement Auto Lighting Ford Mustang 2010-Current

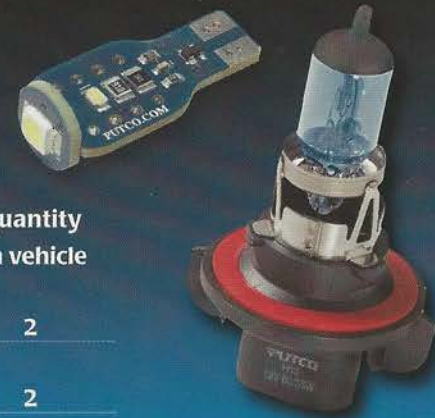

Interior Lighting	Bulb	Quantity on vehicle
Trunk	N/A	N/A
License	1.50 FESTOON	2
Vanity	N/A	N/A
Map	194	2
Glove Box	N/A	N/A



Exterior Lighting	Bulb	Quantity on vehicle
Headlight	H13 / D3S	2
Fog Light	H10 / H11	2
Front Side Marker	194	2
Rear Side Marker	194	2
Reverse	921	2
Front Turn Signal	N/A	N/A
Rear Turn Signal	N/A	N/A
Tail light	N/A	N/A



Also available for many other popular vehicles



*Air intake
Exhausts
Fuel Systems
Ignition
Control
Engine Parts
Tuners
Performance
Handling
Wheels & Tires
Body Styling
Vehicle
Protection
and more.*



Parts for the Modern American Muscle Cars!

MODERN

